

# JUMO mTRON T

## Measuring, Control, and Automation System

### Digital Input/Output Module 12-Channel

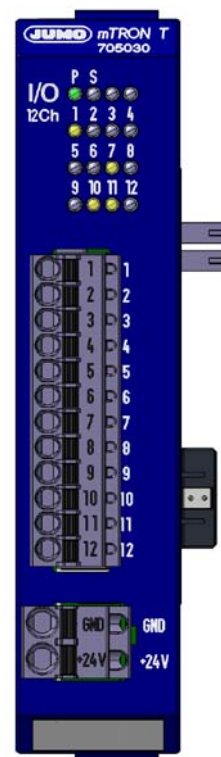

## Operating Manual

70503000T90Z001K000

V2.00/EN/00575632





<b>1</b>	<b>Introduction</b>	<b>.5</b>
1.1	Available technical documentation	5
1.1.1	General information	5
1.1.2	Base units	5
1.1.3	Input/output modules	6
1.1.4	Special modules	6
1.1.5	Operating, visualization, recording	7
1.1.6	Power supply units	7
1.2	Safety information	8
1.2.1	Warning symbols	8
1.2.2	Note signs	8
1.2.3	Intended use	9
1.2.4	Qualification of personnel	9
1.3	Acceptance of goods, storage, and transport	10
1.3.1	Checking the delivery	10
1.3.2	Notes on storage and transport	10
1.3.3	Returning goods	10
1.3.4	Disposal	11
1.4	Identifying the Device Version	12
1.4.1	Nameplates	12
1.4.2	Order details	13
1.4.3	Scope of delivery	13
1.4.4	General accessories	14
<b>2</b>	<b>Description</b>	<b>.15</b>
2.1	Brief description	15
2.2	Block diagram	15
<b>3</b>	<b>Mounting</b>	<b>.17</b>
3.1	General information on installation/dismounting	17
3.2	Installation/dismounting on DIN rail	18
3.2.1	Input/output modules	19
3.3	Replacing module inserts	22
3.3.1	Input/output modules	22
3.4	Dimensions	24
<b>4</b>	<b>Electrical connection</b>	<b>.25</b>
4.1	Installation notes	25
4.2	Electrical isolation	26
4.3	Connection diagram	26
4.3.1	Display and connection elements	27
4.3.2	Digital input	28
4.3.3	Digital outputs	28

# Contents

---

- 4.4 Functional test ..... 29
  
- 5 Operation .....31**

  - 5.1 Display and connection elements ..... 31
  - 5.2 LED displays ..... 32

    - 5.2.1 Display modes ..... 32
    - 5.2.2 System states and errors ..... 33

  
- 6 Configuration .....35**

- 6.1 Digital inputs/outputs ..... 35

  - 6.1.1 Alarm ..... 37

- 6.2 NV connecting list ..... 38

  - 6.2.1 Digital signals (overview) ..... 39
  - 6.2.2 Replacement values (overview) ..... 44

  
- 7 Online parameters .....45**

- 7.1 Calibrate / test ..... 45

  - 7.1.1 Digital output ..... 45
  - 7.1.2 Digital input ..... 46
  - 7.1.3 Versions ..... 47

  
- 8 Appendix .....49**

- 8.1 Technical data ..... 49

  - 8.1.1 Digital inputs and outputs ..... 49
  - 8.1.2 Electrical data ..... 49
  - 8.1.3 Case and ambient conditions ..... 50
  - 8.1.4 Approval/approval marks ..... 50

- 8.2 China RoHS ..... 51

## 1.1 Available technical documentation

The documents specified below are available for the measuring, control, and automation system (previous document number in parentheses).

### 1.1.1 General information

Product	Type of documentation	No.	Printed	PDF file
Measuring, control, and automation system	Data sheet	70500000T10...	-	X
	System manual <sup>1</sup>	70500000T90... (B 705000.0)	X	-
	Setup program manual	70500000T96... (B 705000.6)	-	X
	System description <sup>2</sup>	70500000T98... (B 705000.8)	-	X

<sup>1</sup> Accessory subject to charge

<sup>2</sup> Includes an overview of the purpose and content of all documents

### 1.1.2 Base units

Product	Type of documentation	No.	Printed	PDF file
Central processing unit	Data sheet	70500100T10...	-	X
	Operating manual	70500100T90... (B 705001.0)	-	X
	Modbus interface description	70500100T92... (B 705001.2.0)	-	X
	PROFIBUS-DP interface description	70500103T92... (B 705001.2.3)	-	X
	digiLine interface description	70500106T92...	-	X
	Installation instructions	70500100T94... (B 705001.4)	X	X
	CODESYS OPC server operating manual	70500151T90... (B 705001.5.1)	-	X
	Process engineering application operating manual	70500152T90...	-	X
	Operating manual Thyristor power controller (type 70906x; integration in the measuring, control, and automation system)	70500153T90...	-	X

# 1 Introduction

---

## 1.1.3 Input/output modules

Product	Type of documentation	No.	Printed	PDF file
Multichannel controller module	Data sheet	70501000T10...	-	X
	Operating manual	70501000T90... (B 705010.0)	-	X
	Installation instructions	70501000T94... (B 705010.4)	X	X
Relay module 4-channel	Data sheet	70501500T10...	-	X
	Operating manual	70501500T90... (B 705015.0)	-	X
	Installation instructions	70501500T94... (B 705015.4)	X	X
Analog input module 4-channel	Data sheet	70502000T10...	-	X
	Operating manual	70502000T90... (B 705020.0)	-	X
	Installation instructions	70502000T94... (B 705020.4)	X	X
Analog input module 8-channel	Data sheet	70502100T10...	-	X
	Operating manual	70502100T90... (B 705021.0)	-	X
	Installation instructions	70502100T94... (B 705021.4)	X	X
Analog output module 4-channel	Data sheet	70502500T10...	-	X
	Operating manual	70502500T90...	-	X
	Installation instructions	70502500T94...	X	X
Digital input/output module 12-channel	Data sheet	70503000T10...	-	X
	Operating manual	70503000T90... (B 705030.0)	-	X
	Installation instructions	70503000T94... (B 705030.4)	X	X

## 1.1.4 Special modules

Product	Type of documentation	No.	Printed	PDF file
Router module	Data sheet	70504000T10...	-	X
	Installation instructions	70504000T94... (B 705040.4)	X	X

## 1.1.5 Operating, visualization, recording

Product	Type of documentation	No.	Printed	PDF file
Multifunction panel 840	Data sheet	70506000T10...	-	X
	Operating manual	70506000T90... (B 705060.0)	-	X
	Modbus interface description	70506000T92... (B 705060.2.0)	-	X
	Installation instructions	70506000T94... (B 705060.4)	X	X
Operating panels	Data sheet	70506500T10...	-	X
	Operating manual	70506500T90...	-	X

## 1.1.6 Power supply units

Product	Type of documentation	No.	Printed	PDF file
24 V power supply units	Data sheet	70509000T10...	-	X
	Operating instructions QS5.241		X	-
	Operating instructions QS10.241		X	-

# 1 Introduction

---

## 1.2 Safety information

### 1.2.1 Warning symbols



**DANGER!**

This symbol indicates that **personal injury caused by electrical shock** may occur if the respective precautionary measures are not carried out.



**WARNING!**

This symbol in connection with the signal word indicates that personal injury may occur if the respective precautionary measures are not carried out.



**CAUTION!**

This symbol in connection with the signal word indicates that **damage to assets or data loss** will occur if the respective precautionary measures are not taken.



**CAUTION!**

This symbol indicates that **components could be destroyed** by electrostatic discharge (ESD = Electro Static Discharge) if the respective cautionary measures are not taken. Only use the ESD packages intended for this purpose to return device inserts, assembly groups, or assembly components.



**READ DOCUMENTATION!**

This symbol – placed on the device – indicates that the associated **device documentation has to be observed**. This is necessary to recognize the kind of the potential hazards as well as the measures to avoid them.

### 1.2.2 Note signs



**NOTE!**

This symbol refers to **important information** about the product, its handling, or additional use.



**REFERENCE!**

This symbol refers to **further information** in other sections, chapters, or manuals.



**FURTHER INFORMATION!**

This symbol is used in the tables and refers to **further information** in connection with the table.



**DISPOSAL!**

This device and the batteries (if installed) must not be disposed in the garbage can after use! Please ensure that they are disposed properly and in an **environmentally friendly manner**.

## 1.2.3 Intended use

The modules described are intended for measuring, control, and automation tasks in an industrial environment, as described in the technical data. Other uses or uses beyond those defined are not viewed as intended uses.

The modules are built according to the relevant standards and directives as well as the applicable safety regulations. Nevertheless, incorrect use may lead to bodily injury or property damage.

To avoid danger, the modules may only be used:

- For the intended use
- When in good order and condition
- When taking into account the technical documentation provided

Even if a module is used correctly and according to the intended use, it may still cause application-related dangers (e.g. due to missing safety devices or incorrect settings).

## 1.2.4 Qualification of personnel

This document contains the necessary information for the intended use of the modules to which it relates.

It is intended for technically qualified personnel who have received special training and have the appropriate knowledge in the field of automation technology (measuring, process, and control technology).

The appropriate level of knowledge and the technically fault-free implementation of the safety information and warnings contained in the technical documentation provided are prerequisites for risk-free mounting, installation, and startup as well as for ensuring safety when operating the described modules. Only qualified personnel have the required specialist knowledge to correctly interpret and implement the safety information and warnings contained in this document in specific situations.

# 1 Introduction

---

## 1.3 Acceptance of goods, storage, and transport

### 1.3.1 Checking the delivery

- Ensure that the packaging and contents are not damaged
- Check that the delivery is complete using the delivery papers and the order details
- Inform the supplier immediately if there is any damage
- Store damaged parts until clarification is received from the supplier

### 1.3.2 Notes on storage and transport

- Store the module in a dry and clean environment. Observe the admissible ambient conditions (see "Technical data")
- The transport of the module is to be shockproof
- The original packaging provides optimum protection for storage and transport

### 1.3.3 Returning goods

In the event of repair, please return the module in a clean and complete state. Use the original packaging to return goods.

#### ***Accompanying letter for repair***

Please include the completed accompanying letter for repair when returning goods. Do not forget to state the following:

- Description of the application and
- Description of the error that has occurred

The accompanying letter for repair can be downloaded online from the manufacturer's website (use the search function if necessary).

#### ***Protection against electrostatic discharge (ESD)***

(ESD = electrostatic discharge)

To prevent damage from ESD, electronic modules or components must be handled, packaged, and stored in an ESD-protected environment. Measures against electrostatic discharge and electrical fields are described in DIN EN 61340-5-1 and DIN EN 61340-5-2 "Protection of electronic devices from electrostatic phenomena".

When returning electronic modules or components, please note the following:

- Sensitive components must only be packaged in an ESD-protected environment. Workspaces such as this divert electrostatic charges to ground in a controlled manner and prevent static charges due to friction capacities.
- Only use packaging for ESD-sensitive modules/components. These must consist of conductive plastics.

No liability can be assumed for damage caused by ESD.

**CAUTION!**

Electrostatic charges occur in non-ESD protected environments.  
Electrostatic discharges can damage modules or components.  
For transport purposes, use only the ESD packaging provided.

## 1.3.4 Disposal

### Disposing of the device

**DISPOSAL!**

Devices and/or replaced parts should not be placed in the refuse bin at the end of their service life as they consist of materials that can be recycled by specialist recycling plants.

Dispose of the device and the packaging material in a proper and environmentally friendly manner.

For this purpose, observe the country-specific laws and regulations for waste treatment and disposal.

### Disposing of the packaging material

The entire packaging material (cardboard packaging, inserts, plastic film, and plastic bags) is fully recyclable.

# 1 Introduction

---

## 1.4 Identifying the Device Version

### 1.4.1 Nameplates

#### Position

The nameplate (B) is affixed to the module case.

An additional nameplate with reduced information is located on the module insert (A). This duplicate identification is important when replacing a module insert or retrofitting optional modules.

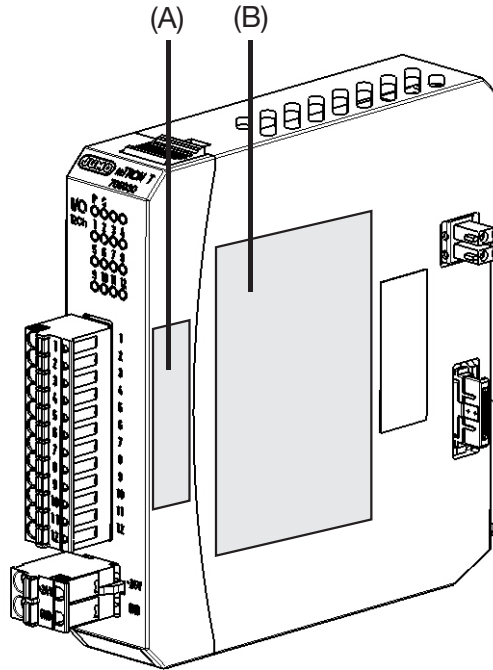

#### Contents

It contains important information. This includes:

Description	Designation on the name-plate	Example
Device type (A + B)	Typ	705030/36
Part no. (B)	TN	00XXXXXX
Fabrication number (A + B)	F-Nr	0070033801211010006
Voltage supply (B)	-	DC 24 V +25/-20 %

#### Device type

Compare the specifications on the nameplate with the order.

Identify the supplied device version using the order details of the respective module.

#### Part no. (TN)

The part no. clearly identifies an article in the catalog. It is important for communication between the customer and the sales department.

## Fabrication no. (F-Nr)

Among other things, the fabrication number contains the date of production (year/week).

Example: F-Nr = 00700338012**1101**0006

The figures concerned are in positions 12, 13, 14, and 15 (from the left).

The device was therefore produced in the 1st calendar week of 2011.

## 1.4.2 Order details

<b>(1) Basic type</b>	
705030	Digital input/output module 12-channel
<b>(2) Voltage supply</b>	
36	DC 24 V +25/-20 %
<b>(3) DNV GL approval</b>	
000	Without approval
062	With DNV GL approval <sup>1</sup>

<sup>1</sup> The power supply unit used must also have a DNV GL or GL type approval (e.g. type 705090).

	<b>(1)</b>		<b>(2)</b>		<b>(3)</b>
Order code	<input type="text"/>	/	<input type="text"/>	/	<input type="text"/>
Order example	705030	/	36	/	000

## 1.4.3 Scope of delivery

1 digital input/output module, 12-channel
1 Installation Instructions

# 1 Introduction

---

## 1.4.4 General accessories

Description	Part no.
JUMO mTRON T system manual, English	00575577
Setup program with program editor JUMO mTRON T (on MiniDVD), incl. USB cable (A-plug to mini-B-plug, 3 m)	00569494
Program editor JUMO mTRON T (on MiniDVD), incl. USB cable (A-plug to mini-B-plug, 3 m)	00622333
PCA3000/PCC JUMO software package	00431884
PC Evaluation Software PCA3000	00431882
Release automatic print for PC Evaluation Software PCA3000	00505548
PCA Communication Software PCC	00431879
Plant Visualization Software JUMO SVS3000: See data sheet 700755	-
USB cable A-plug mini-B-plug 3 m	00506252

Content of the Mini-DVD:

- Setup program with program editor JUMO mTRON T in case of part no. 00569494
- Program editor JUMO mTRON T in case of part no. 00622333
- CODESYS programming software (free version)
- CODESYS Repository Package - Operating panels (free version)
- GSD file JUMO mTRON T - CPU (free version)
- PC Evaluation Software PCA3000 (30-day trial version)
- PCA Communication Software PCC (30-day trial version)
- Documentation in PDF format

### 2.1 Brief description

The module is equipped with 12 channels which can optionally be configured as digital inputs or digital outputs. The digitized input states are available in the system for further processing. The digital outputs are actuated via the system bus by digital signals.

The load current of up to 6 A (12 × max. 500 mA) must be provided via the terminals +24V/ GND at the front.

LEDs are used to indicate applied voltage supply, the module operating status, as well as the digital input/output status.

A setup program or the multifunction panel 840 can be used to comfortably configure the digital input/output module.

For service work, the module insert can be easily pulled out of the case at the front. The case including the bus PCB remains mounted on the DIN rail.

### 2.2 Block diagram

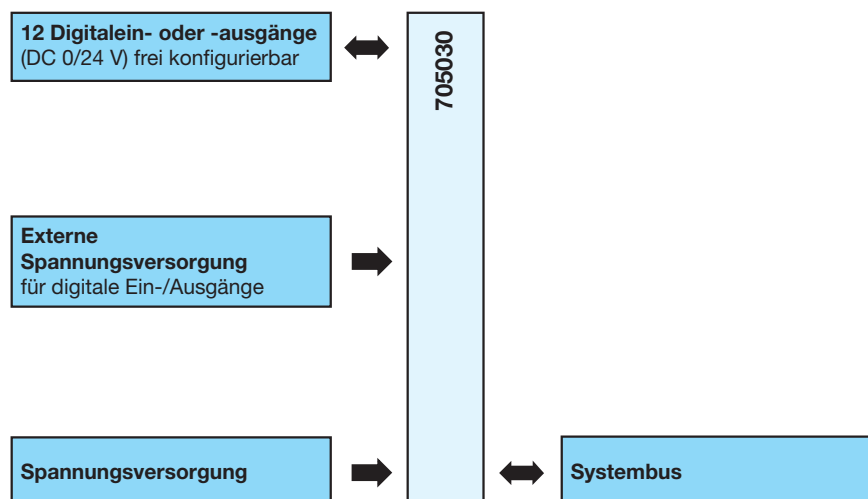

## 2 Description

---

### 3.1 General information on installation/dismounting

**DANGER!**

With multichannel controller module 705010 and relay module 705015, the load circuits from relay or solid state relay outputs can be operated with a dangerous electrical voltage (e.g. 230 V).

There is a risk of electric shock.

Prior to the installation/dismounting of these modules or the removal of the module insert, the load circuits are to be disconnected from the voltage and the terminal strips are to be removed from the module. This work must only be performed by qualified personnel.

**WARNING!**

The modules must never be installed in areas with an explosion hazard.

There is the risk of an explosion.

The entire system must only be used outside of areas with an explosion hazard.

#### Mounting site

All modules have protection type IP20 and are only intended for use in fireproof control cabinets or switch boxes. The mounting site should be virtually vibration-free. Electromagnetic fields caused by equipment such as motors or transformers should be avoided.

Multifunction panel 840 has protection type IP67 at the front and is intended for installation in a panel cut-out. The rear has protection type IP20.

#### Climatic conditions

The ambient temperature and the relative humidity at the mounting site must correspond to the technical data. Aggressive gases and vapors have a negative effect on the operating life of the modules. The mounting site must be free from dust, powder, and other suspended matter so that the cooling slots do not become blocked.

#### DIN rail

All modules are mounted on a DIN rail according to DIN EN 60715 (35 mm × 7.5 mm × 1 mm). For reasons of stability, the spacing of the fastening screws for the DIN rail should not exceed 200 mm. The minimum distances for the modules that are specified in the module-specific installation or operating instructions must be observed.

#### Installation position

The DIN rail should be mounted horizontally so that all modules are arranged vertically. Otherwise the admissible ambient temperature range will be restricted.

#### Space requirement

The modules require the minimum distances shown in the following figure for the purpose of installation/dismounting and for future maintenance or replacement. In the event of shorter distances the minimum bending radius of the cables, the performance of the electrical installation, and the clear arrangement of the plant are no longer guaranteed.

# 3 Mounting

## Minimum distances

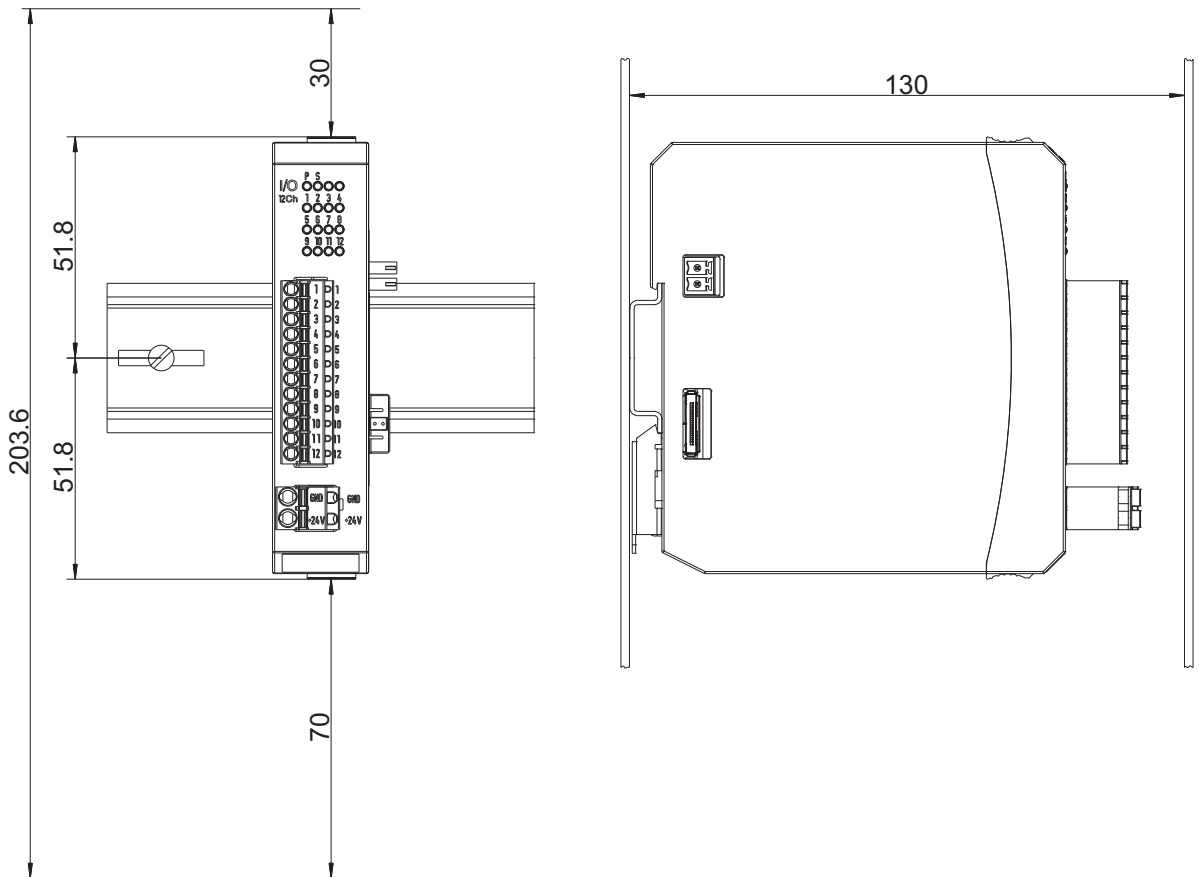

## 3.2 Installation/dismounting on DIN rail

All modules in the system are intended for installation on a DIN rail according to DIN EN 60715 (35 mm × 7.5 mm × 1 mm).

The following must always be installed on the left, at the start of the DIN rail:

- A central processing unit *or*
- A router module

These modules connect the input/output modules to the voltage supply and the system bus.



### NOTE!

To determine the required minimum width of the DIN rail, the widths of the individual modules are to be added (see technical data of the modules in the respective data sheet or the module-specific installation instructions).

The widths of the cover (17.5 mm) and both end brackets (each 9.5 mm) should also be taken into consideration:  $17.5 \text{ mm} + 2 \times 9.5 \text{ mm} = 36.5 \text{ mm}$ .



**NOTE!**

Modules with a recent production date have two fixing knobs on the right side of the case and on the left two round holes (for greater torsional strength of the entire module assembly). If a module with fixing knobs is to be inserted into an existing module assembly and the adjacent module does not have the corresponding holes, the fixing knobs must be completely removed to ensure electrical contact between the modules. For example, a cutter knife and a file can be used for removal.

## 3.2.1 Input/output modules

In a sequence at the user's discretion, input/output modules can be arranged to the right next to a base unit or a router module.

### Installation, using the example of a multichannel controller module 705010

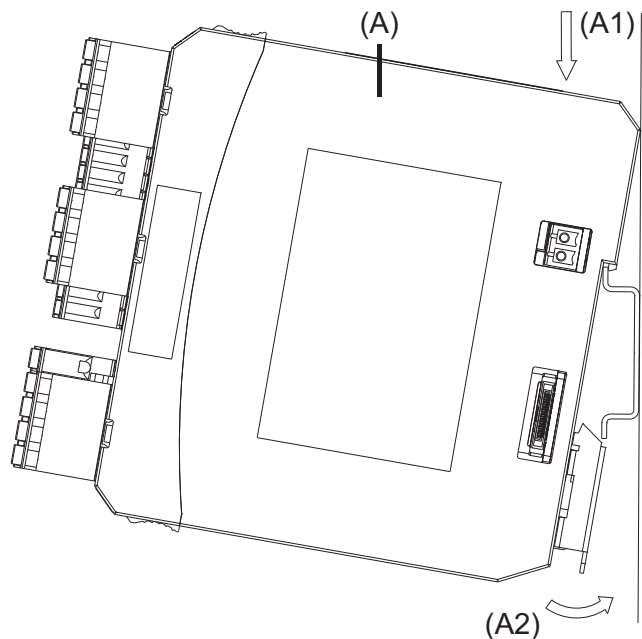

### Example installation

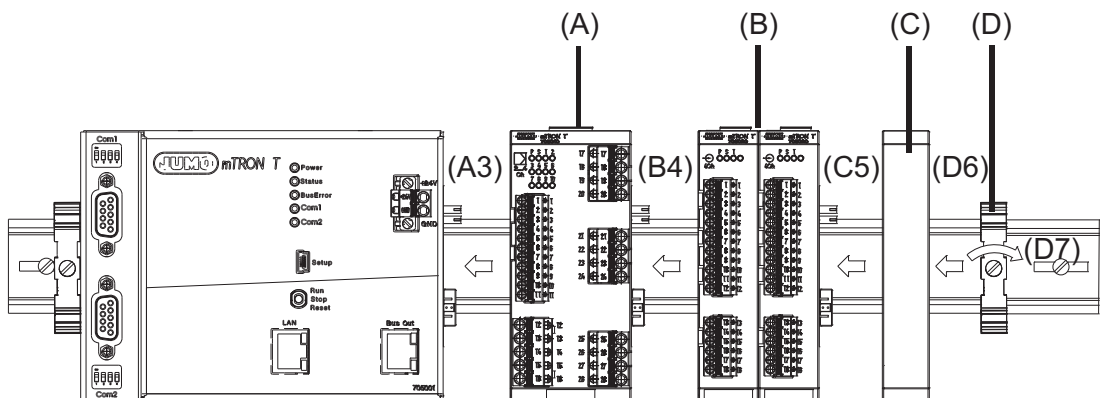

# 3 Mounting

Procedure:

Step	Activity
1	Mount the multichannel controller module (A) in the DIN rail from above (A1).
2	Pivot the multichannel controller module (A) downward until it snaps into place (A2).
3	Move the multichannel controller module (A) to the left against the previous module (A3) until the plug connections for the voltage supply and the system bus are connected.
4	Position additional modules (B) and move to the left against the previous module (B4).
5	After the final module, position the cover (C) on the DIN rail and move to the left against the module (C5).
6	After attaching the cover, position the end bracket (D) on the DIN rail and move to the left against the cover (D6).
7	Fasten the end bracket (D) using a screwdriver (D7). For this purpose, ensure that the end bracket and the cover are positioned flush against the final module.

## Dismounting, using the example of a multichannel controller module 705010

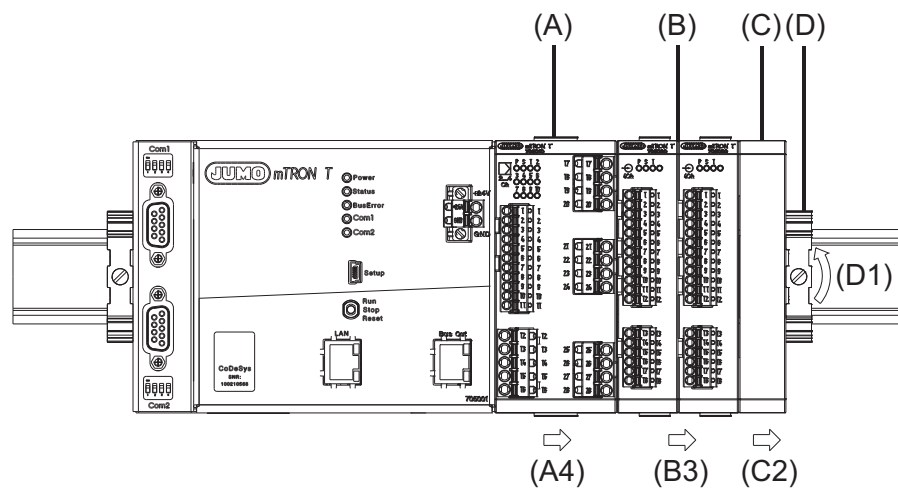

## Removing the multichannel controller module from the DIN rail

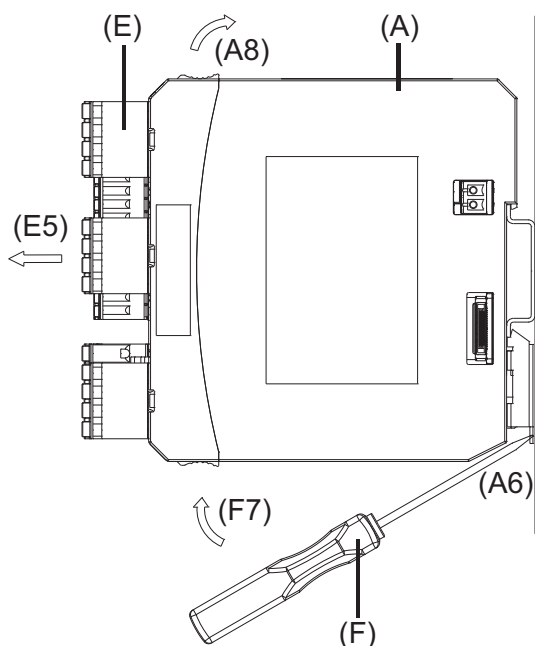

Procedure:

Step	Activity
1	<p>Fully release the end bracket (D) using a screwdriver (D1), press upward from below, pivot toward the front, and remove from the DIN rail.</p> <p>Note: The end bracket does not need to be removed from the DIN rail if there is sufficient space to the side to move it at least 20 mm to the right.</p>
2	<p>Move the cover (C) to the right (C2) until the side contacts of the neighboring module are exposed. Then release the cover at the bottom using a screwdriver, press upward, and remove from the DIN rail.</p> <p>Note: The cover does not need to be removed from the DIN rail if there is sufficient space to the side to move it at least 20 mm to the right.</p>
3	<p>Move the modules (B) on the right next to the multichannel controller module that is to be replaced (A) a minimum of 20 mm to the right (B3).</p> <p>➤ These modules are isolated from the voltage supply and the system bus.</p>
4	<p>Move the multichannel controller module (A) to the right (A4) until the side contacts of the neighboring module (here: central processing unit) – on the left, next to the multichannel controller module that is to be replaced – are exposed.</p> <p>➤ The multichannel controller module is isolated from the voltage supply and the system bus. This is a prerequisite for the dismounting of the multichannel controller module.</p>
5	<p>If required, pull off the wired terminals (E) of the multichannel controller module (A) toward the front (E5).</p>
6	<p>Insert a suitable screwdriver (F) into the unlocking slot of the multichannel controller module (A6) and press upward (F7).</p>
7	<p>Pivot the multichannel controller module (A) upward off the DIN rail (A8) and remove it.</p>

## 3 Mounting

### 3.3 Replacing module inserts

#### 3.3.1 Input/output modules



#### **DANGER!**

With multichannel controller module 705010 and relay module 705015, the load circuits from relay or solid state relay outputs can be operated with a dangerous electrical voltage (e.g. 230 V).

There is a risk of electric shock.

The load circuits are to be disconnected from the voltage supply prior to removing the wired terminal strips. This work must only be performed by qualified personnel.

#### **Replacement of a module insert, using the example of a multichannel controller module 705010**

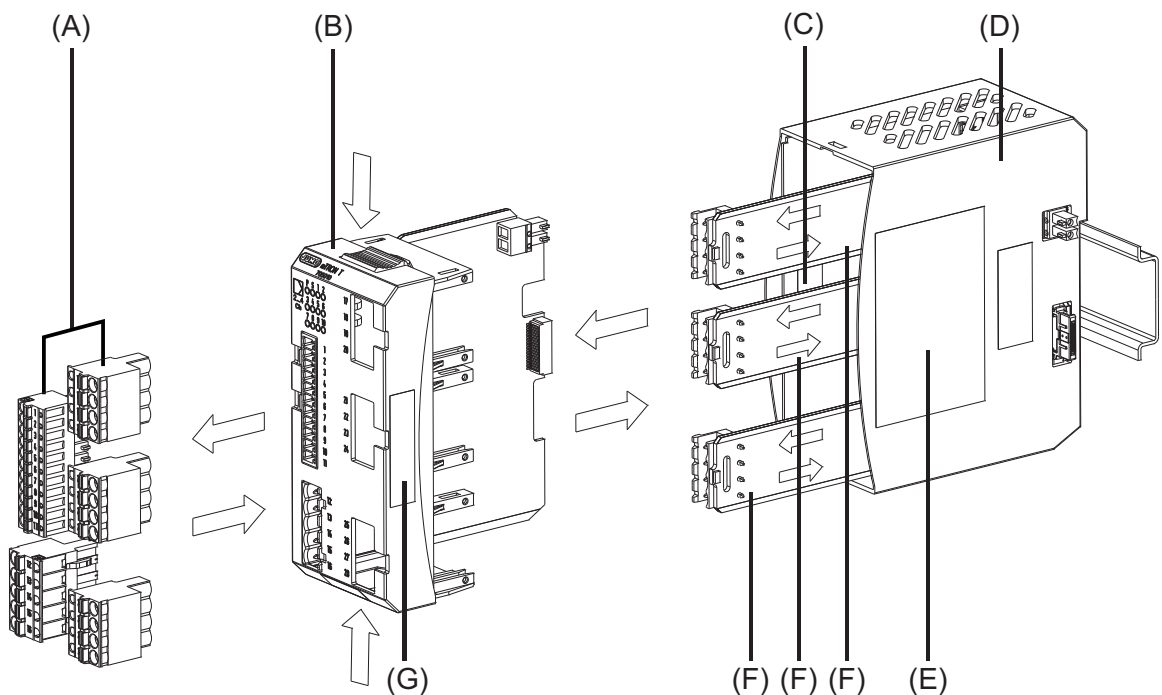

For service purposes (or when retrofitting options for the multichannel controller module), the case (D) can remain in the system; only the module insert (B) is replaced. For this purpose, the system does not need to be isolated from the voltage supply (hot swapping). If it is an optional module, the operation of the rest of the system (mandatory modules) is not interrupted. In the case of a mandatory module, the whole system goes into "Stop" system state (see setup program manual).

The system will detect a module insert of the same type that has been replaced and will automatically reconfigure it. Retrofitted functions for the multichannel controller module (expansion slots) must be configured using the setup program or the multifunction panel.

The new module insert also has a new nameplate (G), which will differ from the old one at least with regard to the fabrication number, and is no longer identical to nameplates (E) and (C) on the case (D).

Therefore, in the event of replacement, the module insert will be supplied along with a new nameplate that will be affixed to the case (D) in place of the old nameplate (C). This means that the specifications of nameplates (G) and (C) once again correspond to one another.



### CAUTION!

Only module inserts of the same type may be used for the replacement. Otherwise, the function of the system may be affected. The module inserts can be clearly identified using the nameplate.



### CAUTION!

With the multichannel controller module 705010, a new module insert may contain retrofitted inputs or outputs that have not yet been configured. This can lead to unintended behavior, particularly at the outputs and the actuators connected to them. Prior to using the retrofitted inputs or outputs, ensure that these have been configured correctly.

### Removing the module insert

Step	Activity
1	Disconnect load circuits from the relay or solid state relay outputs.
2	Pull off the wired terminal strips (A) toward the front.
3	Press the old module insert (B) together on the grooved surfaces at the top and bottom and remove from the case (D).
4	For the multichannel controller module, also remove the modules (F) of the expansion slots from the case (D) toward the front, if required.

### Mounting the module insert

Step	Activity
1	Affix the new nameplate in place of the old nameplate (C) in the case.
2	For the multichannel controller module, also insert the modules (F) of the expansion slots into the case (D), if required.
3	Hold the new module insert (B) at the grooved surfaces on the top and bottom and insert them into the case (D). For this purpose, ensure that the board of the module insert slides into the guide rails of the case. For the multichannel controller module, also ensure that the modules (F) of the expansion slots slide in the guide rails of the module insert.
4	Reattach the wired terminal strips (A).



### NOTE!

When mounting the module insert, ensure that the snap holders (under the grooved surfaces) audibly snap into place.



### NOTE!

The availability of the system can be increased through the storage of module inserts and modules for expansion slots.

# 3 Mounting

---

## 3.4 Dimensions

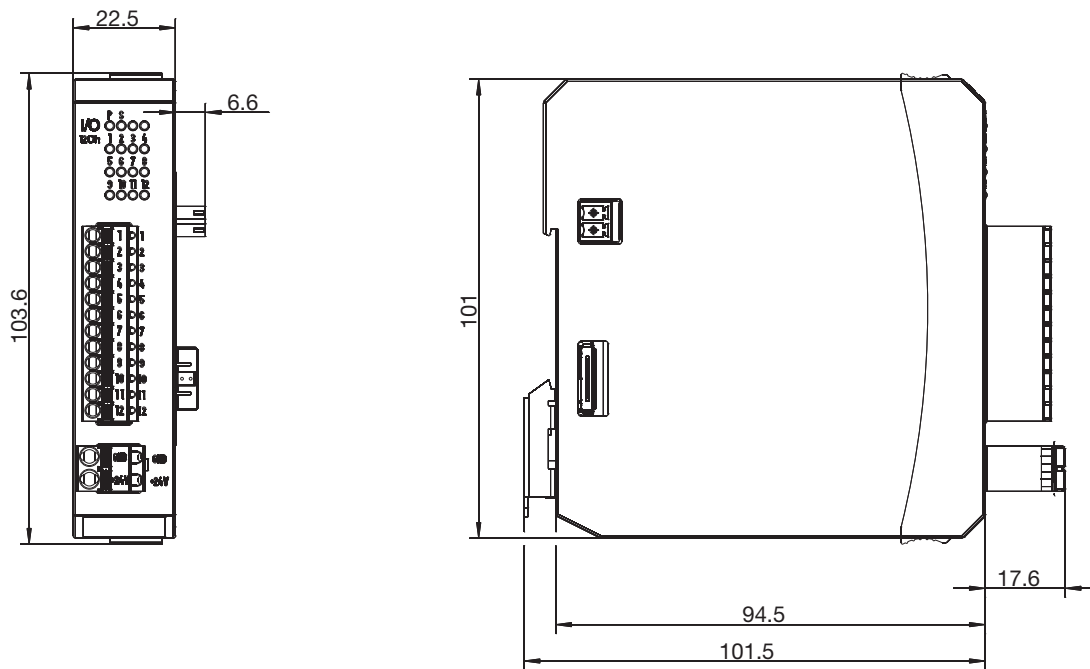

## 4.1 Installation notes



### NOTE!

These installation notes apply for the entire measuring, control, and automation system and, on some occasions, are only applicable for a specific module.

The respective connection diagram shows the context.

### Requirements for the personnel

- Work on the modules must only be carried out to the extent described and, like the electrical connection, only by qualified personnel.
- Before plugging and unplugging connection cables ensure that the person performing the work is electrostatically discharged (e.g. by touching grounded metallic parts).

### Cables, shielding, and grounding

- When selecting the cable material, when installing, and when performing the electrical connection of the module, the regulations of DIN VDE 0100 "Erection of power installations with rated voltages up to 1000 V" and the respective national regulations (e.g. on the basis of IEC 60364) are to be observed.
- Certain cables must be heat resistant up to at least 80 °C at maximum load. The relevant instructions in the connection diagram of the affected modules must be observed.
- Route input, output, and supply cables separately and not parallel to one another.
- Only use shielded and twisted probe and interface cables. Do not route the lines close to current-carrying components or cables.
- For temperature probes, ground the shielding on one side in the control cabinet.
- Do not perform loophroughs on the grounding cables, but route the cables individually to a shared grounding point in the control cabinet; in doing so, ensure that the cables are as short as possible.  
Ensure that the equipotential bonding is correct.

### Electrical safety

- Isolate power supply units from the voltage supply on the primary side if there is a risk of touching parts with dangerous electrical voltage (e.g. 230 V) in the course of work.
- The fuse rating of the power supply units on the primary side should not exceed a value of 10 A (inert).
- With modules with relay or solid state relay outputs, the load circuits can be operated with a dangerous electrical voltage (e.g. 230 V). Disconnect load circuits from the voltage supply during installation/dismounting and electrical connection.
- In order to prevent the destruction of the relay or solid state relay outputs in the event of an external short circuit in the load circuit, the load circuit should be fused to the maximum admissible output current.
- The modules are not suitable for installation in areas with an explosion hazard.
- In addition to a faulty installation, incorrectly set values on the module could also impair the correct function of the following process. Therefore, ensure that safety devices independent of the module (e.g. overpressure valves or temperature limiters/monitors) are available and that it is only possible for qualified personnel to define settings. Please observe the corresponding safety regulations in this context.

## 4 Electrical connection

### References to other information

- The electromagnetic compatibility meets the standards and regulations cited in the technical data.
- The USB device interface and voltage supply in the central processing unit 705001 are **not** electrically isolated. In general, please observe the specifications regarding electrical isolation.

### 4.2 Electrical isolation

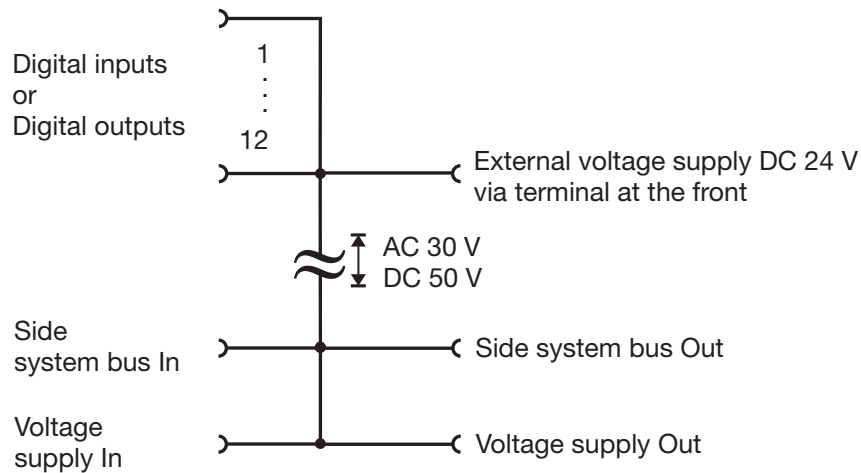

#### NOTE!

The external voltage supply for the digital input/output module 12-channel and the voltage supply for controlling the digital inputs of this module must be switched on/off with a common disconnecting device (common electrical circuit).

### 4.3 Connection diagram



#### CAUTION!

At maximum load, the temperature may exceed 60 °C at the terminals. As a result the insulation of the cable may be damaged. The cable must be heat resistant up to at least 80 °C.



#### CAUTION!

Connecting the external voltage supply DC 24 V via the terminals at the front (terminals "GND" and "+24V"): Ensure that the polarity is correct!



#### CAUTION!

The voltage of the digital outputs depends on the external voltage supply. In case of undervoltage, no voltage is provided at the digital outputs. Observe the technical data for the external voltage supply!



### CAUTION!

Signals to the several digital inputs must have the same ground reference.  
Otherwise undefined signal levels can occur.  
Ground reference via terminal "GND" required!

### 4.3.1 Display and connection elements

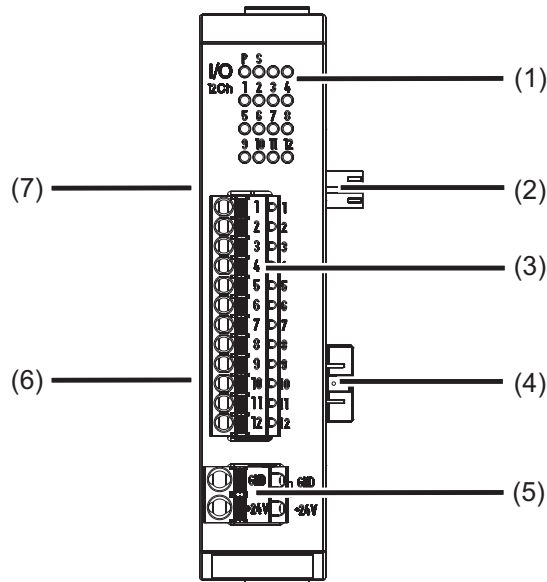

(1) Status displays (LED)

P = Voltage supply

S = Status

1 to 12 = Digital input/output  
(LED is lit: Active)

(2) Voltage supply Out, DC 24 V

(3) Digital inputs/outputs

(4) Side system bus Out

(5) External voltage supply  
DC 24 V

(6) Side system bus In

(7) Voltage supply In, DC 24 V

## 4 Electrical connection

### 4.3.2 Digital input

The connection depends on the configuration (input or output).

Connection	Input	Terminals	Symbol and terminal designation
Apply signal DC 0/24 V to terminals 1 to 12	1 2 3 4 5 6 7 8 9 10 11 12	1 and GND 2 and GND 3 and GND 4 and GND 5 and GND 6 and GND 7 and GND 8 and GND 9 and GND 10 and GND 11 and GND 12 and GND	
Ground reference via GND terminal required!			
Or:			
Switch DC 24 V from terminal +24 V to terminals 1 to 12 via floating contact.	1 2 3 4 5 6 7 8 9 10 11 12	1 and +24 V 2 and +24 V 3 and +24 V 4 and +24 V 5 and +24 V 6 and +24 V 7 and +24 V 8 and +24 V 9 and +24 V 10 and +24 V 11 and +24 V 12 and +24 V	
External voltage supply DC 24 V via terminals +24 V and GND required!			

### 4.3.3 Digital outputs

The connection depends on the configuration (input or output).

Connection	Output	Terminals	Symbol and terminal designation
Output signal: DC 0/24 V / maximum 500 mA	1 2 3 4 5 6 7 8 9 10 11 12	1 and GND 2 and GND 3 and GND 4 and GND 5 and GND 6 and GND 7 and GND 8 and GND 9 and GND 10 and GND 11 and GND 12 and GND	
External voltage supply DC 24 V via terminals +24 V and GND required!			

### 4.4 Functional test

The **voltage supply** must be tested on completion of the electrical connection:

Signal	Meaning
LED "P" (Power, green) <b>is lit</b>	The module is being supplied with voltage through the side contacts.
LED "P" (Power, green) <b>is not lit</b>	<p>The module is not supplied with voltage or there is a problem with the electrical function of the LED.</p> <p>Remedy:</p> <ul style="list-style-type: none"><li>• Check the voltage supply to the side contacts of the preceding module (top contact +24 V, bottom contact GND).</li><li>• Check voltage supply at the "+24 V" and "GND" terminals of the base unit or router module.</li><li>• Check power supply unit and connection between the power supply unit and the base unit or router module.</li></ul> <p>If the "Power" LED does not light up despite a voltage supply being present, the module insert or – if the bus board inside the case is faulty – the entire module must be replaced.</p>

#### Startup

The check described above completes the process of installation and electrical connection. For startup, use the additional documentation (operating manual or system manual).

The "Introduction" section of this document contains an overview of all documentation for the measuring, control, and automation system.

## 4 Electrical connection

---

## 5.1 Display and connection elements

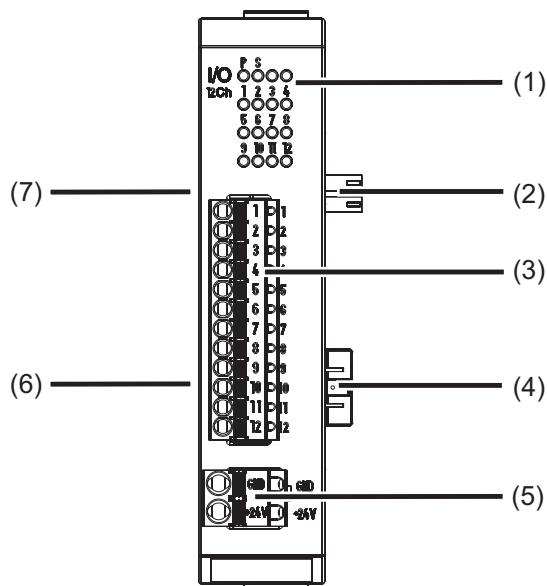

- (1) Status displays (LED)
  - P = Voltage supply
  - S = Status
  - 1 to 12 = Digital input/output  
(LED is lit: Active)
- (2) Voltage supply Out, DC 24 V
- (3) Digital inputs/outputs
- (4) Side system bus Out
- (5) External voltage supply  
DC 24 V
- (6) Side system bus In
- (7) Voltage supply In, DC 24 V

# 5 Operation

## 5.2 LED displays

### "P" LED (Power)

The LED is permanently lit in green if the module is being supplied with voltage.

### "S" LED (Status)

This LED indicates the status of the module. Diagnostics requires the setup program or a Web browser as appropriate.

### LEDs "1" to "12"

The LEDs indicate the status of the relevant digital input or output.

- LED is not lit = input or output is inactive (Low level)
- LED is lit (yellow) = input or output is active (High level)

### 5.2.1 Display modes

The following table lists all possible states of the "S" LED (Status).

Display mode	Description	Green symbol	Red symbol
---	LED state not relevant	---	---
Off	LED off	○	○
On	LED on (permanently lit)	■	●
Flickering	LED flickers (50 ms on, 50 ms off)	■ ■ ■ ■ ■	● ● ● ● ●
Single flickering	LED flashes briefly (50 ms on, 200 ms off)	■ □ □ □ □	● ○ ○ ○ ○
Blinking	LED flashes (200 ms on, 200 ms off)	■ □ ■ □ ■	● ○ ● ○ ●
Single flash	LED flashes once (200 ms on, 1000 ms off)	■ □ □	● ○ ○
Double flash	LED flashes twice (on/off/on for 200 ms each time, 1000 ms off)	■ ■ □ □	● ● ○ ○
Triple flash	LED flashes three times (on/off/on/off/on for 200 ms each time, 1000 ms off)	■ ■ ■ □ □	● ● ● ○ ○
Quadruple flash	LED flashes four times (on/off/on/off/on/off/on for 200 ms each time, 1000 ms off)	■ ■ ■ ■ □ □	● ● ● ● ○ ○
Blinking red/green	LED flashes red and green (200 ms red, 200 ms green)	● ■ ● ■	
On green/ Single flickering red	LED lights up green, flashes red (50 ms red)	■ ●	

## 5.2.2 System states and errors

The following table lists all the system states and errors that are indicated by the "S" LED (Status). In most cases, further diagnostics must be performed with the setup program.

Category	"S" LED (Status)	Meaning	Diagnostics with	Recommended action
Bus status	○	No connection to central processing unit	LED	Check whether the central processing unit is running; check cabling and topology
Bus status	○	System in "Stop" (INIT) state – no error, only in start phase	LED	
Bus status	■ □ ■ □ ■	System in "Stop" (PREOP) state – no error, only in start phase	LED	
Operation	■ □ □ (Priority 3)	System in "Stop" (SAFEOP) state – no error	LED	
Operation	■ (Priority 3)	System in "Run" (OP) state – no error	LED	

## 5 Operation

---



**NOTE!**

The parameters described in this section can be configured either with the setup program or with the multifunction panel.

## 6.1 Digital inputs/outputs

The digital input/output module has 12 channels, each of which can be configured as digital input or digital output.

The digital outputs are actuated by assigned external inputs (NV\_DO01 to NV\_DO12).

Assigned external inputs (NV\_SR01 to NV\_SR12) are also used to suppress the signals of the digital inputs.

⇒ Chapter 6.2 "NV connecting list", page 38

### Setup dialog

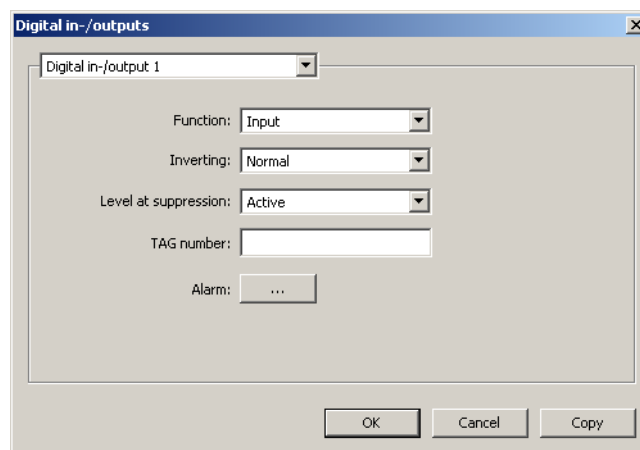

### Parameters

Parameters	Selection/settings	Description
Function	<b>Input</b>	The relevant channel is configured as input.
	Output	The relevant channel is configured as output.
Inverting	Inverting of the input signal or the output signal (depending on the configuration of the channel)	
	<b>Normal</b> Inverse	Not inverted Inverted
Level at suppression 	Input signal level during active signal suppression	
	Inactive <b>Active</b>	Low level (0) High level (1)
TAG number	7 characters (as of system version 05: 42 characters)	Identification marking (documentation in PLC)

## 6 Configuration

---

### **Level at suppression**

When signal suppression is active, the input signal and the inverting parameter are irrelevant. In this case, a fixed signal with a configurable level is issued (to the system bus).

### **Status after change of configuration**

Modified parameters are incorporated immediately.

### **Behavior after power on**

After power on, all channels of the digital input/output module are initially configured as input. When the initialization phase is over and valid values of the external input signals are available, the outputs are activated (according to the configuration).

## 6.1.1 Alarm

Signal monitoring can be activated for each digital input.

### Setup dialog

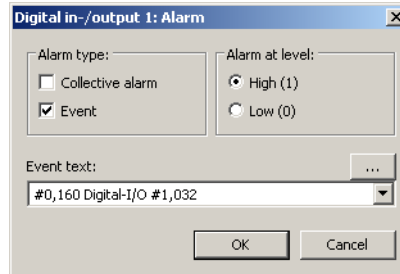

### Parameters

Parameters	Selection/settings	Description
Alarm type	The alarm type is <b>not</b> set by default.	
	Collective alarm	Alarm results in collective alarm of the module.
	Event	Alarm results in an entry (event text) in the event list.
Alarm active at	<b>High (1)</b>	Alarm at high level (1)
	Low (0)	Alarm at low level (0)
Event text 	Use default text or select other text from the list.	Text that is entered in the event list for an alarm (if Alarm type = "Event").

### Event text

**Setup program:** Selection of text from a list

Click the "..." button to open a list with the text numbers and the associated texts. The texts can be edited.

**Multifunction panel:** Selection of text using the text number

The setup program is required to view and edit the texts.

# 6 Configuration

## 6.2 NV connecting list

The NV connecting list is used to link external inputs (NV\_...) of the digital input/output module to signals from other modules via the system bus.

A comprehensive list with the module signals is included in the following chapter:

⇒ Chapter 6.2.1 "Digital signals (overview)", page 39

Further information about the signals can be found in the operating manual for the relevant module.

Replacement values are available in the event that these signals are not available (connection to base unit interrupted or system in "Stop" state).

⇒ Chapter 6.2.2 "Replacement values (overview)", page 44



**NOTE!**

There is no NV connecting list in the input/output module configuration menu on the multi-function panel. Instead, a central NV connecting list is available in the configuration menu of the base unit (CPU).

### Setup dialog

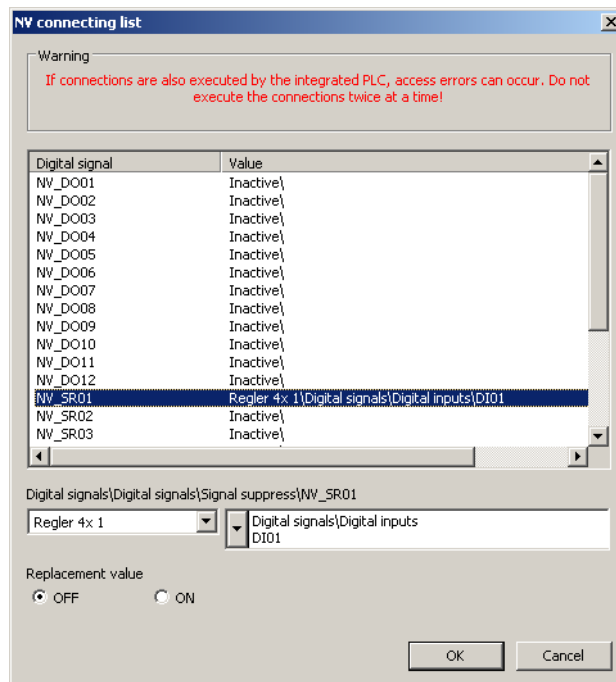

### Parameters

Parameters	Selection/settings	Description
Digital signal / Value	Select input to be connected.	List of external inputs of the module If a connection has already been configured, the module and its signal are displayed in the "Value" column.
...\NV_SR01 (Example)	This is the previously selected external input. Select the module and – in the selector next to it on the right – the signal to connect to the external input.	List of modules in the system and the relevant signals

Parameters	Selection/settings	Description
Replacement value	Replacement value for the relevant signal (The selection On/Off is active if a signal is assigned to the external input.)	
	Off	Low level (0)
	On	High level (1)

## Replacement value

The replacement value is used if the relevant signal is not available (connection to base unit interrupted or system in "Stop" state).

## Status after change of configuration

The connections are available immediately.

## Behavior after power on

The connections are available immediately after system initialization.

### 6.2.1 Digital signals (overview)

The following table contains all signals that are available in the NV connecting list for connection to the external inputs (NV\_...) of the digital input/output module.

Category	Signal	Description
Inactive		No signal selected
<b>Central processing unit</b>		
Digital variables	Digital variable 1 to 64	Digital variable 1 to 64 (via interface)

## 6 Configuration

Category	Signal	Description
Program generator 1 to Program generator 9	Operating contact 1 to 16	Operating contact 1 to 16 of program channels (in the three program channels, operating contacts with the same name are linked with OR)
	Mode: Basic status	Status: Program is not running (basic status)
	Mode: Automatic	Status: Program is running (automatic mode, no delay time or program end time)
	Mode: Automatic 1	Status: Program is running (automatic mode, incl. delay time and program end time)
	Mode: Standstill	Status: Program stopped during automatic mode (time base stopped)
	Mode: Delay	Status: Program start delayed (delay time runs)
	Mode: Program end	Status: Program ends (program end time runs, corresponds to length of end signal)
	Mode: Manual	Status: Manual mode
	Tolerance band channel 1 to 3	Tolerance band signal of program channel 1 to 3
	Batch control	Signal to control the batch recording (OR-linked signals "Automatic", "Standstill", and "Program end").
PLC Binary output 28 to 32	Signal of PLC digital output 28 to 32	
Limit monitoring	Limit monitoring 1 to 64	Output signal of limit value monitoring 1 to 64
Binary linking	Binary linking 1 to 8	Result of binary linking 1 to 8
	PLC Binary output 9 to 32	Signal of PLC digital output 9 to 32
Binary PLC output block 13 to block 18	PLC Binary output 1 to 32	Signal of PLC digital output 1 to 32
Alarm analog variables	Alarm1 ExAI1 to Alarm1 ExAI64	Alarm signal 1 of analog variable 1 to 64
	Alarm2 ExAI1 to Alarm2ExAI64	Alarm signal 2 of analog variable 1 to 64
Alarm integer variables	Alarm1 ExInt1 to Alarm1 ExInt64	Alarm signal 1 of integer variable 1 to 64
	Alarm2 ExInt1 to Alarm2ExInt64	Alarm signal 2 of integer variable 1 to 64

## 6 Configuration

Category	Signal	Description
Alarms/ Faults	CAlarm/Fault	System collective alarm or system fault (central processing unit and modules)
	CAlarm/Fault ackn.	System collective alarm or system fault with acknowledgement Signal remains active until acknowledgement.
	CAlarm device	System collective alarm (central processing unit and modules)
	CAlarm ackn.	System collective alarm with acknowledgement Signal remains active until acknowledgement.
	Fault	System fault (central processing unit and modules)
	Fault ackn.	System fault with acknowledgement Signal remains active until acknowledgement.
	CAlarm Basis	Central processing unit collective alarm
	System Run	System state (Run = 1, Stop = 0)
	Reserve 1	(Reserved for future use.)
	Fieldbus error	Error at fieldbus interface
	System error mandatory	Error in a mandatory module
	System error optional	Error in an optional module
	No PLC	No PLC program available
	PLC stop	„Stop“ system state
	Battery empty	Battery alarm (central processing unit buffer battery is dead and must be replaced) Notify service department! Attention: RAM memory content is deleted!
	Battery low	Battery pre-warning (central processing unit buffer battery can be replaced within 4 weeks without data loss) Notify service department!

## 6 Configuration

Category	Signal	Description
<b>Multichannel controller module</b>		
Controller	C01ManualMode to C04ManualMode	Manual mode active for controller channel 1 to 4
	C01TuneActive to C04TuneActive	Self-optimization active for controller module 1 to 4
	C01Output1 to C04Output1	Switch position of first controller output of controller channel 1 to 4
	C01Output2 to C04Output2	Switch position of second controller output of controller channel 1 to 4
	C01CollAlarm to C04CollAlarm	Collective alarm of controller channel 1 to 4 (can be configured with signals from the digital selector)
Setpoint	SP01RampTolBand to SP04RampTolBand	Alarm signal of tolerance band monitoring of ramp function 1 to 4
	SP01Changeover1 to SP04Changeover1	Bit 0 of setpoint changeover of setpoint value function 1 to 4
	SP01Changeover2 to SP04Changeover2	Bit 1 of setpoint changeover of setpoint value function 1 to 4
Analog inputs	AI01Alarm1 to AI04Alarm1	Alarm signal 1 of analog input 1 to 4
	AI01Alarm2 to AI04Alarm2	Alarm signal 2 of analog input 1 to 4
Digital inputs	DI01, DI02, DI05 to DI10	Signal of digital input 1, 2, 5 to 10 If the HW counter is activated, the signal of digital input 1 is inactive.
Limit monitoring	LI01 to LI04	Output signal of limit value monitoring 1 to 4
Mathematics	Logic01 to Logic04	Result of logic function 1 to 4
Miscellaneous	CollectiveAlarm	Controller module collective alarm
	HWCounterSignal	Signal of hardware counter in "fill" operating mode (as shut-down signal when threshold value reached)

## 6 Configuration

Category	Signal	Description
<b>Analog input module 4-channel</b>		
Analog inputs	AI01Alarm1 to AI04Alarm1	Alarm signal 1 of analog input 1 to 4
	AI01Alarm2 to AI04Alarm2	Alarm signal 2 of analog input 1 to 4
Digital inputs	DI01	Signal of digital input
Alarm	CollectiveAlarm	Module collective alarm
<b>Analog input module 8-channel</b>		
Analog inputs	AI01Alarm1 to AI08Alarm1	Alarm signal 1 of analog input 1 to 8
	AI01Alarm2 to AI08Alarm2	Alarm signal 2 of analog input 1 to 8
Digital inputs	DI01	Signal of digital input
Alarm	CollectiveAlarm	Module collective alarm
<b>Digital input/output module 12-channel</b>		
Digital inputs	DI01 to DI12	Signal of digital input 1 to 12
Alarm	CollectiveAlarm	Module collective alarm
<b>Multifunction panel 840</b>		
System bus digital inputs	Alarm batch 1 to Alarm batch 9	Collective alarm of batch 1 to 9 (process values)
	CollectiveAlarm	Collective alarm of multifunction panel (process values)
	Fault	Fault in multifunction panel (independent of process values)
	Batch 1 active to Batch 9 active	Signal for active batch 1 to 9
	Push button 1 to Push button 18 (as of system version 02: 1 to 32)	Status of push button 1 to 18 (as of system version 02: 1 to 32) in process screen

## 6 Configuration

Category	Signal	Description
<b>Thyristor power controller, type 70906x</b>		
Device status	Individual digital signals of the power controller: See operating manual 70500153T90... (or following table)	Device status signals
Faults master		Faults of the power controller in single-phase operation or of the master in case of three-phase economy circuit or three-phase circuit
Faults slave/ slave1		Faults of the slave in case of three-phase economy circuit or of slave 1 in case of three-phase circuit
Faults slave2		Faults of slave 2 in case of three-phase circuit
Faults master slave		Faults of master slave connection and communication
Hardware input/ output		Binary values of hardware inputs and outputs

### 6.2.2 Replacement values (overview)

The following table contains the replacement values with their factory settings. Replacement values can only be configured in the setup program.

#### Digital signals

Category	Signal	Factory setting	Description
Signal suppression	Signal suppression 1 to 9 NV_SR01 to NV_SR09	Off	Signal for activating signal suppression



**NOTE!**

An active connection between the setup program and the central processing unit is required to configure the parameters described in this section.

## 7.1 Calibrate / test



**CAUTION!**

Incorrect settings may result in inadmissible changes to values. This can have negative effects on the system function. This function must be used only by (or under the instruction of) a service technician of the device manufacturer.

### 7.1.1 Digital output

**Setup dialog**

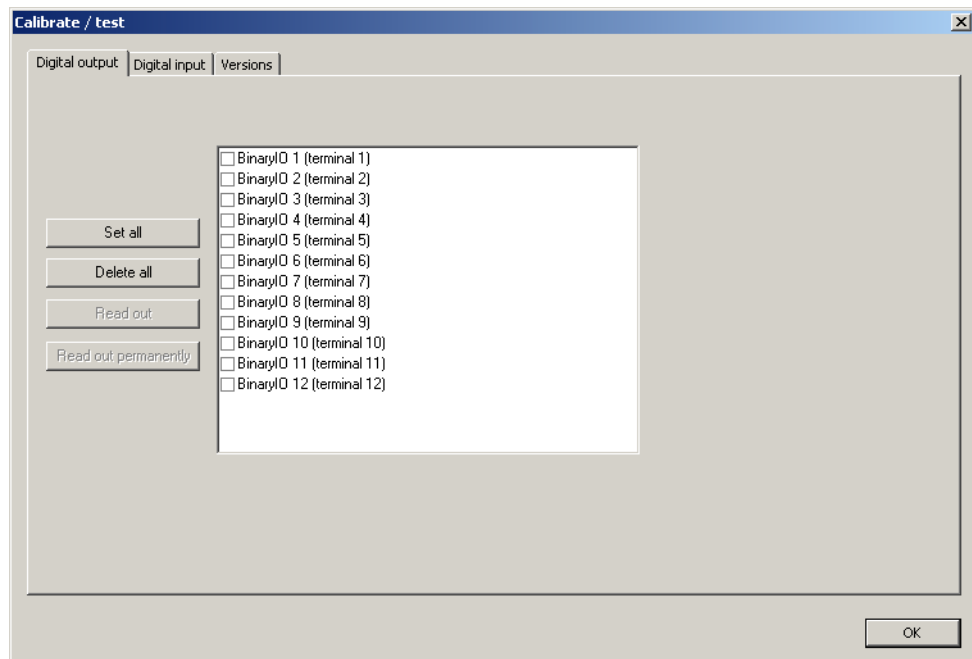

**Parameters**

Parameters	Selection/settings	Description
BinaryIO 1 to BinaryIO 12	Select digital output (activate checkbox). You can select multiple outputs simultaneously.	The selected digital output changes to active state (High level).
Set all	Click the "Set all" button.	All digital outputs change to active state (High level).
Delete all	Click the "Delete all" button.	All digital outputs change to inactive state (Low level).

# 7 Online parameters

## 7.1.2 Digital input

### Setup dialog

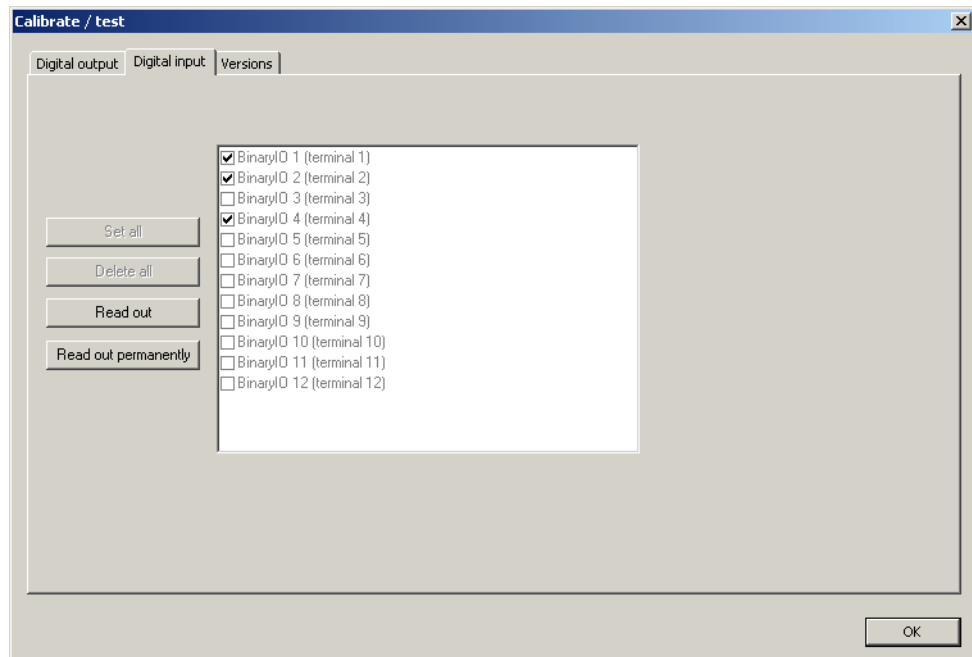

### Parameters

Parameters	Selection/settings	Description
Read out	Click the "Read out" button.	The current status of the digital inputs is read out. Active inputs are marked with a check mark.
Read out permanently	Click the "Read out permanently" button	The current status of the digital inputs is read out permanently (until the user aborts). Active inputs are marked with a check mark.

### 7.1.3 Versions

#### Setup dialog

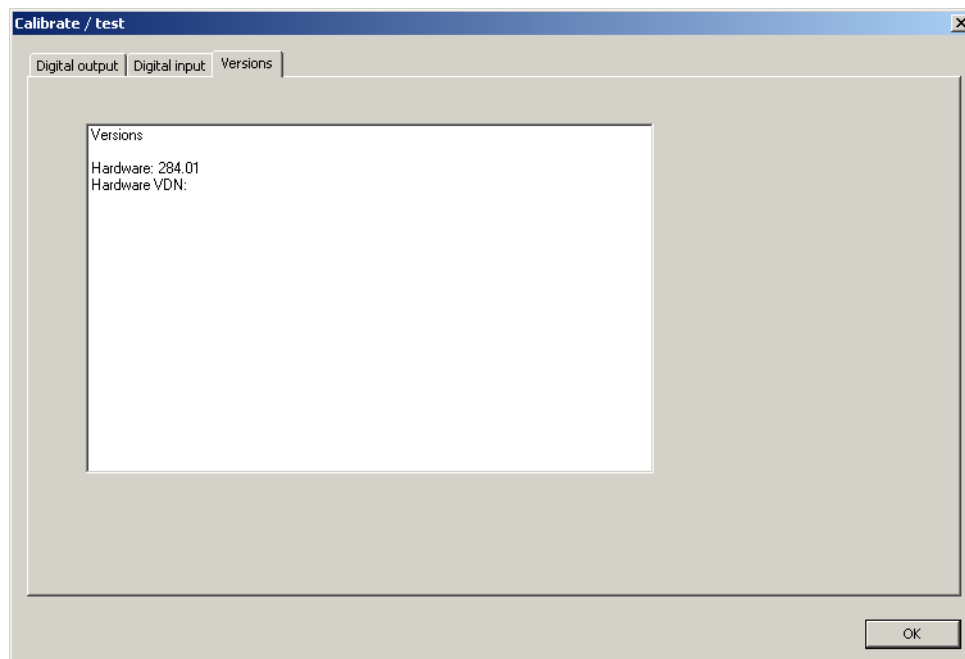

This dialog displays the module versions.

## 7 Online parameters

---

## 8.1 Technical data

### 8.1.1 Digital inputs and outputs

Number	12
Digital inputs	
Input signal	DC 0/24 V (PLC level; logical "0" = -3 to +5 V; logical "1" = +15 to +30 V)
Current	Max. 5 mA per input
Digital outputs	
Output signal	DC 0/24 V (depending on external voltage supply)
Current	Max. 500 mA per output, short-circuit proof

### 8.1.2 Electrical data

Voltage supply	For module electronics
Connection	Lateral (feed via base unit or router module)
Voltage	DC 24 V +25/-20 %
Residual ripple	5 %
External voltage supply	For digital inputs/outputs
Connection	At the front
Voltage	DC 24 V +25/-20 % SELV
Current	Max. 6 A
Short-circuit protection	6.3 A (internal fuse)
Current consumption	90 mA (module electronics only; at DC 19.2 V)
Power consumption	2 W (module electronics only)
Inputs or outputs (terminals 1 to 12) and external voltage supply (2-pole terminal GND/+24 V)	At the front (removable terminal strips with Push-In technology)
Conductor cross section on terminals 1 to 12	
Wire or strand without ferrule	Min. 0.14 mm <sup>2</sup> , max. 1.5 mm <sup>2</sup>
Strand with ferrule	Without plastic collar: Min. 0.25 mm <sup>2</sup> , max. 1.5 mm <sup>2</sup>
Strand with ferrule	With plastic collar: Min. 0.25 mm <sup>2</sup> , max. 0.5 mm <sup>2</sup>
Stripping length on terminals 1 to 12	9 mm
Conductor cross section on terminals GND and +24 V	
Wire or strand without ferrule	Min. 1.5 mm <sup>2</sup> , max. 2.5 mm <sup>2</sup>
Strand with ferrule	Min. 1.5 mm <sup>2</sup> , max. 2.5 mm <sup>2</sup>
2x strand with twin ferrule with plastic collar	1.5 mm <sup>2</sup>
Stripping length on terminals GND and +24 V	10 mm
Electrical safety	Acc. to DIN EN 61010-1 Overvoltage category III, pollution degree 2
Electromagnetic compatibility	Acc. to DIN EN 61326-1
Interference emission	Class A – only for industrial use –
Interference immunity	Industrial requirements

## 8 Appendix

---

### 8.1.3 Case and ambient conditions

Case type	Plastic case for DIN rail mounting in the control cabinet (indoor use); DIN rail acc. to DIN EN 60715, 35 mm x 7.5 mm x 1 mm
Dimensions (W x H x D)	22.5 mm x 103.6 mm x 101.5 mm (without connection elements)
Weight	Approx. 130 g
Protection type	IP20, acc. to DIN EN 60529
Ambient temperature range	-20 to +55 °C
Storage temperature range	-40 to +70 °C
Resistance to climatic conditions	Relative humidity ≤ 90 % annual average without condensation (climatic class 3K3 acc. to DIN EN 60721-3-3 with extended temperature and humidity range)
Site altitude	Up to 2000 m above sea level
Mechanical ambient conditions <sup>1</sup>	Classification acc. to DIN EN 60721-3-3, table 6, class 3M2

<sup>1</sup> Test conditions are listed in the System Descripton B 705000.8.

### 8.1.4 Approval/approval marks

Approval mark	Testing agency	Certificate/certification number	Inspection basis	Valid for
c UL us	Underwriters Laboratories	E201387	UL 61010-1 (3. Ed.), CAN/CSA-22.2 No. 61010-1 (3. Ed.)	all types
DNV GL	DNV GL	TAA000016N	Class Guideline DNVGL-CG-0339	all types; a power supply unit with DNV GL or GL type approval is required (e.g. type 705090)

## 8.2 China RoHS

 产品组别 Product group: 705030 部件名称 Component Name	产品中有害物质的名称及含量 China EEP Hazardous Substances Information					
	铅 (Pb)	汞 (Hg)	镉 (Cd)	六价铬 (Cr(VI))	多溴联苯 (PBB)	多溴二苯醚 (PBDE)
外壳 Housing (Gehäuse)	○	○	○	○	○	○
过程连接 Process connection (Prozessanschluss)	○	○	○	○	○	○
螺母 Nuts (Mutter)	○	○	○	○	○	○
螺栓 Screw (Schraube)	○	○	○	○	○	○

本表格依据SJ/T 11364的规定编制。  
 This table is prepared in accordance with the provisions SJ/T 11364.  
 ○：表示该有害物质在该部件所有均质材料中的含量均在GB/T 26572规定的限量要求以下。  
 Indicate the hazardous substances in all homogeneous materials' for the part is below the limit of the GB/T 26572.  
 x：表示该有害物质至少在该部件的某一均质材料中的含量超出GB/T 26572规定的限量要求。  
 Indicate the hazardous substances in at least one homogeneous materials' of the part is exceeded the limit of the GB/T 26572.







**JUMO GmbH & Co. KG**

Street address:  
Moritz-Juchheim-Straße 1  
36039 Fulda, Germany

Delivery address:  
Mackenrodtstraße 14  
36039 Fulda, Germany

Postal address:  
36035 Fulda, Germany

Phone: +49 661 6003-0  
Fax: +49 661 6003-607  
Email: [mail@jumo.net](mailto:mail@jumo.net)  
Internet: [www.jumo.net](http://www.jumo.net)

**JUMO Instrument Co. Ltd.**

JUMO House  
Temple Bank, Riverway  
Harlow, Essex, CM20 2DY, UK

Phone: +44 1279 63 55 33  
Fax: +44 1279 62 50 29  
Email: [sales@jumo.co.uk](mailto:sales@jumo.co.uk)  
Internet: [www.jumo.co.uk](http://www.jumo.co.uk)

**JUMO Process Control, Inc.**

6733 Myers Road  
East Syracuse, NY 13057, USA

Phone: +1 315 437 5866  
Fax: +1 315 437 5860  
Email: [info.us@jumo.net](mailto:info.us@jumo.net)  
Internet: [www.jumousa.com](http://www.jumousa.com)

