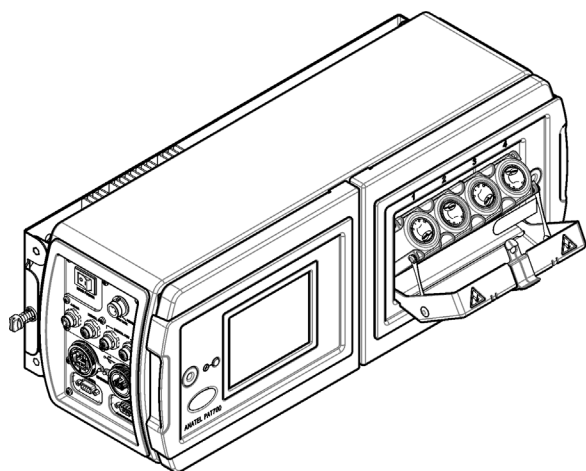




# Instruction For Use

## PAT700 DS

Total Organic Carbon Analyzer



DOC026.53.80298 Edition 4  
October 2022



Beckman Coulter, Inc.  
250 S. Kraemer Blvd.  
Brea, CA 92821 U.S.A.



**PAT700**  
**Instructions for Use**

DOC026.53.80298 Edition 4 (October 2022)

© 2022 Beckman Coulter, Inc.  
All rights reserved.

Beckman Coulter, the stylized logo, and the Beckman Coulter product and service marks mentioned herein are trademarks or registered trademarks of Beckman Coulter, Inc. in the United States and other countries.

All other trademarks are the property of their respective owners.

**Contact Us**

If you have any questions, contact our Customer Support Center.

- Worldwide, find us via our website at [www.beckman.com/support/technical](http://www.beckman.com/support/technical).
- In Austria, call us at 0810 300484
- In Germany, call us at 02151 333999
- In Sweden, call us at +46 (0)8 564 859 14
- In the Netherlands, call us at +31 348 799 815
- In France, call us at 0825838306 6
- In the UK, call us at +44 845 600 1345
- In Ireland, call us at +353 (01) 4073082
- In Italy, call us at +39 0295392 456
- In other locales, contact your local Beckman Coulter Representative.



Beckman Coulter Eurocenter S.A.  
22, rue Juste-Olivier  
Case Postale 1044  
CH - 1260 Nyon 1, Switzerland  
Tel: +41 (0) 22 365 36 11



Beckman Coulter (UK) Ltd.  
Oakley Court  
Kingsmead Business Park, London Road  
High Wycombe  
United Kingdom HP11 1JU  
01494 441181

*May be covered by one or more pat. - see  
[www.beckman.com/patents](http://www.beckman.com/patents)*

Glossary of Symbols is available at  
[beckman.com/techdocs](http://beckman.com/techdocs) (PN C24689).

Original Instructions

# Revision History

## **Edition 3, 10/17**

Updates were made to the following sections:

### **CHAPTER 2, *General Information***

Use of Hazard Information

Precautionary Labels

### **CHAPTER 3, *Installation***

Connect the 4–20 mA Output

Connect the Discrete Outputs

### **CHAPTER 4, *User Interface and Navigation***

Setup Menu

### **CHAPTER 6, *Basic Operation***

Export or Print Data

### **CHAPTER 7, *Advanced Operation***

Configure the Network Settings

Configure the FTP Function

Configure Active Directory Settings

Add, Delete or Change Users

## **Edition 4, 9/22**

Updates were made to the following sections:

### **CHAPTER 2, *General Information***

[Precautionary Labels](#)

[铭牌 \(Name Rating Plate\)](#)

NOTE: Changes that are part of the most recent revision are indicated by a bar in the margin of the amended page.

*This document applies to the latest software listed and higher versions. When a subsequent software version affects the information in this document, a new issue will be released to the Beckman Coulter Web site. For labeling updates, go to [www.beckman.com](http://www.beckman.com) and download the latest version of the manual or system help for your instrument.*



# Contents

	Revision History, iii
<b>CHAPTER 1:</b>	Specifications, 1-1
	Specifications, 1-1
<b>CHAPTER 2:</b>	General Information, 2-1
	Safety Information, 2-1
	Use of Hazard Information, 2-2
	Safety Precautions, 2-3
	General Safety Considerations, 2-3
	EMC Information, 2-4
	Precautionary Labels, 2-4
	Certification, 2-6
	FCC Conformance for RFID, 2-7
	Product Overview, 2-7
	Product Components, 2-8
<b>CHAPTER 3:</b>	Installation, 3-1
	Installation Guidelines, 3-1
	Mechanical Installation, 3-2
	Attach the Instrument to a Wall, 3-2
	Attach the Instrument to Dual Pipes, 3-3
	Electrical Installation, 3-4
	Wiring Safety Information, 3-4
	About Quick-Connect Wiring Connections, 3-4
	Connect the Power Cord, 3-4
	Connect the 4–20 mA Output, 3-5
	Connect the Discrete Inputs, 3-5
	Connect the Discrete Outputs, 3-5
	Connect a 40-Column Printer, 3-6
	Set the Printer DIP Switches, 3-6
	Plumbing, 3-8
	Plumb the Instrument, 3-8
<b>CHAPTER 4:</b>	User Interface and Navigation, 4-1
	Sliding Toolbar, 4-1

Setup Menu, 4-2

## **CHAPTER 5: Startup, 5-1**

Connect to Power, 5-1

Set the Sample Flow Rate, 5-1

## **CHAPTER 6: Basic Operation, 6-1**

Select the Run Mode, 6-1

Calibration, 6-1

TOC Calibration, 6-1

Conductivity Calibration, 6-2

Do a System Suitability Test, 6-4

Measure a Grab Sample, 6-5

Manage Measurement Data, 6-6

Set the Data Filter, 6-6

Export or Print Data, 6-6

## **CHAPTER 7: Advanced Operation, 7-1**

Select the Source Stream, 7-1

TOC Operating Mode Configuration, 7-1

Configure the General Settings, 7-1

Configure the Flow During Idle Mode, 7-2

Configure Digital Control, 7-3

Enable the Stabilization Process, 7-4

Set the TOC Offset, 7-5

System Configuration, 7-5

Set the Analyzer Name, Location and Language, 7-5

Set the Date, Time and Units, 7-6

Configure the Alarm Sounds, 7-7

Configure the Backlight Settings, 7-7

Configure the Digital Output Alarms, 7-8

Conductivity Alarm Limit, 7-9

Configure the Network Settings, 7-10

Configure the FTP Function, 7-11

Configure Active Directory Settings, 7-13

Configure the Analog Outputs, 7-14

Configure the Printer Settings, 7-15

Security Configuration, 7-16

Enable Security and Data Logging, 7-16

Set Password Expiration and Automatic Log Off, 7-17

Add, Delete or Change Users, 7-17

About Backdoor Passwords, 7-19

- Show the Audit Trail, 7-19
- Bottle Mode Configuration, 7-20
  - Configure the TOC Calibration Settings, 7-20
  - Configure the Conductivity Calibration Settings, 7-21
  - Set the Analyzer to Return to Online Mode, 7-22
- Bottle Mode Operation, 7-23
  - Validate the TOC Calibration, 7-23
  - Get an Excursion Sample, 7-24
  - Flush the Sample Bottle Lines, 7-25
- CHAPTER 8: Maintenance, 8-1**
  - Maintenance Schedule, 8-1
  - Clean the Instrument, 8-1
  - Clean Leaks and Spills, 8-2
  - Replace a Fuse, 8-3
  - Drain the Instrument, 8-4
  - Send the Instrument for Service, 8-5
- CHAPTER 9: Troubleshooting, 9-1**
  - Alarms, 9-1
    - Alarm Indication, 9-1
    - Accept or Remove an Alarm, 9-2
      - Error Codes, 9-2
      - Critical Error Codes, 9-3
      - Warning Codes, 9-4
      - Measurement Alarm Codes, 9-5
  - Diagnostics, 9-6
    - Review the Data Log Usage and Firmware Version, 9-6
    - Review the UV Lamp Information, 9-6
    - Do a Lamp Test, 9-7
    - Change to the other UV Lamp, 9-7
    - Select a Diagnostic Test, 9-7
      - Validate the RS232 Connection, 9-8
      - Validate the Digital I/O Communication, 9-8
      - Validate the 4-20 mA Output, 9-9
      - Do a Printer Test, 9-9
      - Do a Plumbing Test, 9-9
      - Validate the Pump Operation, 9-11
      - Do an RFID Test, 9-12
      - Do a Fan Test, 9-12
      - Calibrate the Display, 9-13
    - See the Calibration Dates, 9-13
  - Technical Support, 9-14

**APPENDIX A: Appendix, A-1**

Theory of Operation, A-1

Analyzer Startup Sequence, A-2

Run Modes, A-3

The Analysis Cycle, A-3

Online TOC Mode, A-3

Conductivity Mode, A-3

Standby Mode, A-4

Offline Mode, A-4

Manual TOC Sample, A-4

Self-Clean Mode, A-4

Bottle Mode, A-4

Calibration and Validation, A-4

Onboard Automated Standards Introduction System (OASIS), A-5

RFID Technology, A-5

Data Log, A-6

Default Settings, A-6

**APPENDIX B: Replacement Parts and Accessories, B-1**

Consumables, B-1

Replacement Parts, B-1

Accessories, B-2

铭牌 (Name Rating Plate), 1

Related Documents



# Illustrations

2.1	Instrument Components, 2-8
3.1	Installation Dimensions, 3-2
3.2	Wall Mount, 3-3
3.3	Pipe Installation, 3-3
3.4	Power Supply and Wire Connections, 3-4
3.5	Plumb the Instrument, 3-10
4.1	Home Screen, 4-1
5.1	Flow Control Valve, 5-2
6.1	Calibration Resistor, 6-3
8.1	Fuse Location, 8-4
A.1	PAT700 Theory of Operation, A-1

# Tables

2.1	Registration Information, 2-7
3.1	4–20 mA Terminal Designations, 3-5
3.2	Discrete Input Designations, 3-5
3.3	Discrete Output 1 and 2, 3-6
3.4	Discrete Output 3 and 4, 3-6
3.5	Printer DIP Switch 1 Settings, 3-7
3.6	Printer DIP Switch 2 Settings, 3-7
3.7	Printer DIP Switch 3 Settings, 3-8
4.1	Sliding Toolbar Options, 4-1
4.2	Setup Menu Options, 4-2
7.1	Digital Output – Default States, 7-9
7.2	Conductivity Alarm Limit, 7-9
8.1	Maintenance Schedule, 8-1
9.1	Error Codes, 9-2
9.2	Critical Error Codes, 9-3
9.3	Warning Codes, 9-4
9.4	Measurement Alarm Conditions, 9-6
A.1	Parameters and Default Settings, A-6

## Specifications

Specifications are subject to change without notice.

Specification	Details
Dimensions (W x D x H)	59.7 x 22.9 x 25.4 cm (23.5 x 9 x 10 in.)
Enclosure	IP46
Weight	13.6 kg (30 lb)
Pollution degree	2
Installation category	II
Protection class	I
Power requirements	100/230 VAC, $\pm 10\%$ , 65 W, 50/60 Hz
Altitude	4000 m (13,125 ft) maximum
Operating temperature	10 to 40 °C (50 to 104 °F)
Humidity	5–95%, non-condensing
Sample temperature	1 to 95 °C (34 to 203 °F)
Sample flow rate	60 to 300 mL/min
Sample pressure	0.70 to 7.0 kg/cm <sup>2</sup> (10 to 100 psi)
Temperature accuracy	$\pm 0.5$ °C
UV lamps	2x, with UV Detect technology
User interface	Color touch screen
TOC	Range: 0.5 to 2000 ppb as carbon
	Accuracy: $\pm 3$ ppb or $\pm 5\%$ , whichever is greater
	Repeatability: $\pm 0.3$ ppb or $\pm 1\%$ , whichever is greater
	Detection limit: 0.5 ppb
Conductivity	Range for conductivity mode: 0.05 to 150 $\mu\text{S}/\text{cm}$ at 25 °C
	Accuracy: $\pm 2\%$ over the full range
	Range for TOC mode: 0.05–5.0 $\mu\text{S}/\text{cm}$
Outputs	Analog: Three isolated
	Discrete: Four isolated, configurable
Inputs	Discrete: Two isolated
Certifications	CE Certified. Listed to UL and CSA safety standards by ETL.
Warranty	1 year



## CHAPTER 2

# General Information

In no event will the manufacturer be liable for direct, indirect, special, incidental or consequential damages resulting from any defect or omission in this manual. The manufacturer reserves the right to make changes in this manual and the products it describes at any time, without notice or obligation. Revised editions are found on the manufacturer's website.

## Safety Information

---

**IMPORTANT** The manufacturer is not responsible for any damages due to misapplication or misuse of this product including, without limitation, direct, incidental and consequential damages, and disclaims such damages to the full extent permitted under applicable law. The user is solely responsible to identify critical application risks and install appropriate mechanisms to protect processes during a possible equipment malfunction.

Please read this entire manual before unpacking, setting up or operating this equipment. Pay attention to all danger and caution statements. Failure to do so could result in serious injury to the operator or damage to the equipment.

Make sure that the protection provided by this equipment is not impaired. Do not use or install this equipment in any manner other than that specified in this manual.

## Use of Hazard Information

---



Indicates a potentially or imminently hazardous situation which, if not avoided, will result in death or serious injury.



Indicates a potentially or imminently hazardous situation which, if not avoided, could result in death or serious injury.



Indicates a potentially hazardous situation that may result in minor or moderate injury.

**NOTE** NOTE is used to call attention to notable information that should be followed during use or maintenance of this equipment.

**IMPORTANT** Indicates a situation which, if not avoided, may cause damage to the instrument. Information that requires special emphasis.

## Safety Precautions

### WARNING

Risk of operator injury if:

- All doors, covers and panels are not closed and secured in place prior to and during instrument operation.
- The integrity of safety interlocks and sensors is compromised.
- Instrument alarms and error messages are not acknowledged and acted upon.
- You contact moving parts.
- You mishandle broken parts.
- Doors, covers and panels are not opened, closed, removed and/or replaced with care.
- Improper tools are used for troubleshooting.

To avoid injury:

- Keep doors, covers and panels closed and secured in place while the instrument is in use.
- Take full advantage of the safety features of the instrument.
- Acknowledge and act upon instrument alarms and error messages.
- Keep away from moving parts.
- Report any broken parts to your Beckman Coulter Representative.
- Open/remove and close/replace doors, covers and panels with care.
- Use the proper tools when troubleshooting.

## General Safety Considerations

---

### WARNING

Risk of personal injury. Safety protection can be impaired if used in a manner not specified by the manufacturer. To avoid personal injury, use the instrument according to the manufacturer's instructions only.

### CAUTION

Risk of instrument damage. This device is intended for indoor use only. To avoid device damage, do not install the instrument doors.

### WARNING

Risk of personal injury and/or damage to the instrument. Attempts by untrained personnel to disassemble, alter, modify or adjust the electronics may result in

**personal injury and damage to the equipment. To prevent risk of personal injury and/or damage to the instrument, ensure only factory certified personnel perform service of the equipment.**

## EMC Information

This device complies with the emissions and immunity requirements as specified in the EN/IEC 61326 series of Product Family Standards for a “basic electromagnetic environment.” Such equipment is supplied directly at low voltage from public mains network. This equipment is not intended for residential use.



This device generates, uses, and can radiate unintentional radio-frequency (RF) energy. If this device is not installed and operated correctly, this RF energy can cause interference with other equipment. It is the responsibility of the end user to be sure that a compatible electromagnetic environment for the device can be maintained so that the device operates as intended.

In addition, other equipment can radiate RF energy to which this device is sensitive. If one suspects interference between this device and other equipment, Beckman Coulter recommends the following actions to correct the interference:










- Evaluate the electromagnetic environment before installation and operation of this device.
- Do not operate this device close to sources of strong electromagnetic radiation (for example: unshielded intentional RF sources), as these can interfere with proper operation. Examples of unshielded intentional radiators are handheld radio transmitters, cordless phones, and cellular phones.
- Do not place this device near medical electrical equipment that can be susceptible to malfunctions caused by close-proximity to electromagnetic fields.
- This device has been designed and tested to CISPR 11, Class A emission limits. In a domestic environment, this device may cause radio interference, in which case, you may need to take measures to mitigate the interference.

## Precautionary Labels

Read all labels and tags attached to the instrument. Personal injury or damage to the instrument could occur if not observed.

	This symbol, if noted on the instrument, references the instruction manual for operation and/or safety information.
	<p>Electrical equipment marked with this symbol may not be disposed of in European public disposal systems after 12 August of 2005. In conformity with European local and national regulations (EU Directive 2002/96/EC), European electrical equipment users must now return old or end-of-life equipment to the Producer for disposal at no charge to the user.</p> <p><b>NOTE</b> For return for recycling, please contact the equipment producer or supplier for instructions on how to return end-of-life equipment, producer-supplied electrical accessories, and all auxiliary items for proper disposal.</p>



	This symbol indicates that a risk of electrical shock and/or electrocution exists.
	This symbol indicates the need for protective eye wear.
	This symbol indicates that the marked item requires a protective earth connection. If the instrument is not supplied with a ground plug on a cord, make the protective earth connection to the protective conductor terminal.
	This symbol, when noted on the product, identifies the location of a fuse or current limiting device.
	This symbol indicates the presence of mercury. Components that contain mercury must be disposed in accordance with all applicable local and regional law.
	This symbol indicates a puncture or pinch hazard. Keep hands and fingers away.
	This symbol indicates the presence of a UV light source that may cause eye and skin injury. Wear appropriate protective equipment and obey all safety protocols.
	A “CE” mark indicates that a product has been assessed before being placed on the market, and has been found to meet European Union safety, health, and/or environmental protection requirements.
	<p>Recycling Symbol WEEE Wheeled Bin Symbol</p> <p>The symbol of a crossed-out wheeled bin on the product is required in accordance with the Waste Electrical and Electronic Equipment (WEEE) Directive of the European Union. The presence of this marking on the product indicates:</p> <ol style="list-style-type: none"> <li>1. that the device was put on the European Market after August 13, 2005 and</li> <li>2. that the device is not to be disposed via the municipal waste collection system of any member state of the European Union.</li> </ol> <p>For products under the requirement of WEEE directive, please contact your dealer or local Beckman Coulter office for the proper decontamination information and take-back program which will facilitate the proper collection, treatment, recovery, recycling, and safe disposal of device.</p> <p>For the Japan market: This system is considered an industrial waste, subject to special controls for infectious waste. Before disposal of the system, refer to the Waste Disposal and Public Cleaning Law for compliance procedures.</p>

	<p>RoHS Caution Symbol People's Republic of China Electronic Industry Standard SJ/T11364-2006</p> <p>This label indicates that the electronic information product contains certain toxic or hazardous substances. The center number is the Environmentally Friendly Use Period (EFUP) date, and indicates the number of calendar years the product can be in operation. Upon the expiration of the EFUP, the product must be immediately recycled. The circling arrows indicate the product is recyclable. The date code on the label or product indicates the date of manufacture.</p>
	<p>A "UKCA" mark indicates that a product has been assessed before being placed in the UK market, and has been found to meet UK safety, health, and/or environmental protection requirements.</p>

## Certification

### Canadian Radio Interference-Causing Equipment Regulation, IECS-003, Class A:

Supporting test records reside with the manufacturer.

This Class A digital apparatus meets all requirements of the Canadian Interference-Causing Equipment Regulations.

Cet appareil numérique de classe A répond à toutes les exigences de la réglementation canadienne sur les équipements provoquant des interférences.

### FCC Part 15, Class "A" Limits

Supporting test records reside with the manufacturer. The device complies with Part 15 of the FCC Rules. Operation is subject to the following conditions:

1. The equipment may not cause harmful interference.
2. The equipment must accept any interference received, including interference that may cause undesired operation.

Changes or modifications to this equipment not expressly approved by the party responsible for compliance could void the user's authority to operate the equipment. This equipment has been tested and found to comply with the limits for a Class A digital device, pursuant to Part 15 of the FCC rules. These limits are designed to provide reasonable protection against harmful interference when the equipment is operated in a commercial environment. This equipment generates, uses and can radiate radio frequency energy and, if not installed and used in accordance with the instruction manual, may cause harmful interference to radio communications. Operation of this equipment in a residential area is likely to cause harmful interference, in which case the user will be required to correct the interference at their expense. The following techniques can be used to reduce interference problems:

1. Disconnect the equipment from its power source to verify that it is or is not the source of the interference.
2. If the equipment is connected to the same outlet as the device experiencing interference, connect the equipment to a different outlet.
3. Move the equipment away from the device receiving the interference.

4. Reposition the receiving antenna for the device receiving the interference.
5. Try combinations of the above.

## FCC Conformance for RFID

This instrument may contain a registered radio frequency identification device (RFID). Refer to [Table 2.1](#).

**Table 2.1** Registration Information

Parameter	Value
FCC identification number (FCC ID)	VICPAT700TOC
IC	6149A-PT700TOC
For Japan	MIC、この設備は自分自身で証明されます。 MIC証明Number はAC- 2195です
Frequency	13.56 MHz to $\pm 7$ kHz
RF output power	<180 mW

## Product Overview

---



**Chemical or biological hazards. If this instrument is used to monitor a treatment process and/or chemical feed system for which there are regulatory limits and monitoring requirements related to public health, public safety, food or beverage manufacture or processing, it is the responsibility of the user of this instrument to know and abide by any applicable regulation and to have sufficient and appropriate mechanisms in place for compliance with applicable regulations in the event of malfunction of the instrument.**

This analyzer uses UV light to oxidize water samples for TOC analysis in pure and ultra-pure water process applications. The analyzer is capable of compliance to 21 CFR Part 11 with password protection and an audit trail of user actions.

For power and data collection, the analyzer connects to the facility systems through quick-connect connections.

The analyzer has an OASIS bottle bay to measure individual grab samples or do a calibration/validation. Bottle information is read automatically with the radio frequency identification device (RFID) wireless system and RFID tags on the bottles\*.

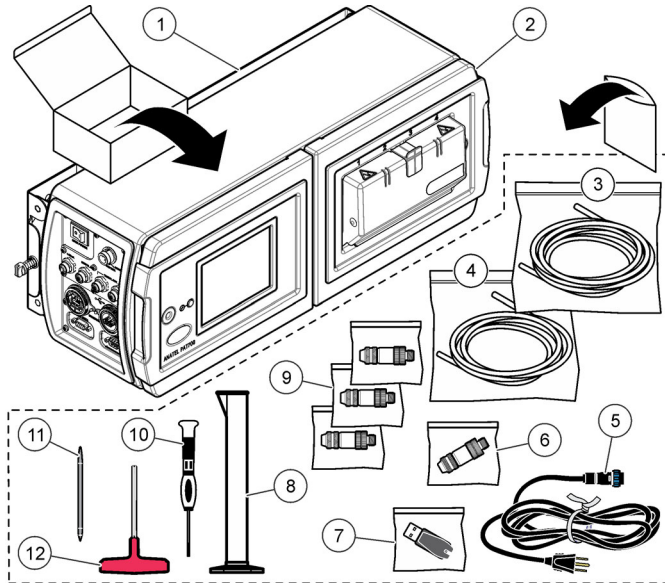
---

\* Not all models include the RFID wireless system

## Product Components

Make sure that all components have been received. Refer to [Figure 2.1](#). If any items are missing or damaged, contact the manufacturer or a sales representative immediately.

**Figure 2.1** Instrument Components



- |                       |                                 |                               |
|-----------------------|---------------------------------|-------------------------------|
| 1. Wall mount bracket | 5. Power cord                   | 9. Connector, I/O, 6-pin (1x) |
| 2. PAT700             | 6. Stylus for touchscreen       | 10. USB flash drive           |
| 3. Tubing, 10 ft      | 7. Screwdriver, 2-mm wide blade | 11. Graduated cylinder, 50-mL |
| 4. Tubing, 5 ft       | 8. Connector, I/O, 5-pin (3x)   | 12. Hex wrench, T-handle      |

## Installation Guidelines

---

 **DANGER**



Fire hazard. This product is not designed for use with flammable liquids.

 **DANGER**



Electrocution hazard. If this equipment is used outdoors or in potentially wet locations, a Ground Fault Circuit Interrupt (GFCI/GFI) device must be used for connecting the equipment to its main power source.

 **WARNING**



Electrical shock hazard. Externally connected equipment must have an applicable country safety standard assessment.

 **WARNING**



Multiple hazards. Only qualified personnel must conduct the tasks described in this section of the document.

**IMPORTANT** To prevent measurement error, make sure that the instrument is attached in an upright, level position.

For environmental and sample requirements, refer to [Specifications](#).

- Put the instrument in a location that has access for operation, service and calibration.
- Install the instrument near the water system sample point.
- Make sure that there is a minimum of 30.48 cm (12 in.) of clearance for the enclosure doors to open. Refer to [Figure 3.1](#).
- Make sure that there is sufficient clearance to access the power switch, plumbing and electrical connections on the end panels. Refer to [Figure 3.1](#).

## Mechanical Installation

### Attach the Instrument to a Wall

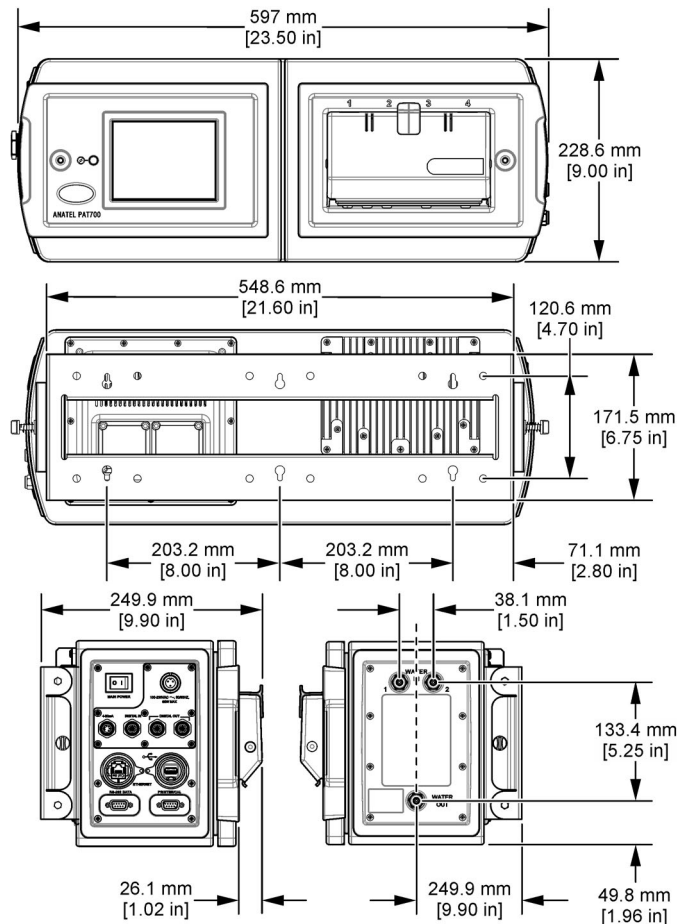


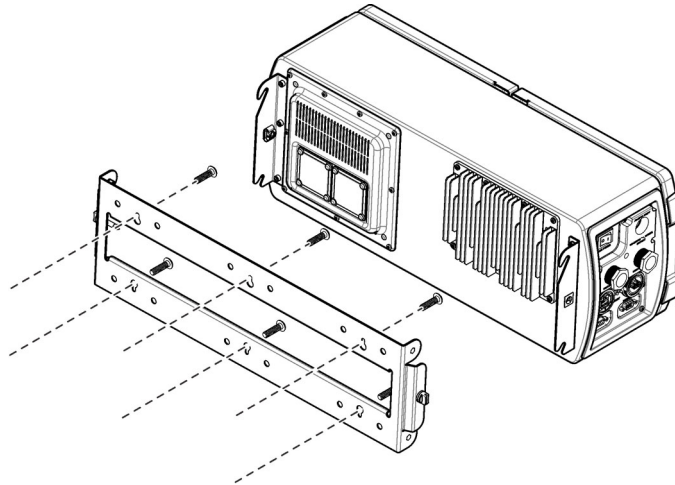
**Personal injury hazard. Make sure that the wall mounting is able to hold 4 times the weight of the equipment.**

Install the instrument on a wall or other stable, flat surface. Refer to [Figure 3.1](#) for dimensions. Refer to [Figure 3.2](#) for installation.

- Use user-supplied 8-mm (5/16-in.) diameter screws or bolts and nuts to attach the instrument to a wall or other flat, rigid surface. Use hardware that is approved for a process environment.
- Do not attach bolts to separate girders, beams or wall studs that can move independently.
- Do not attach the instrument to a surface that has vibration.

**Figure 3.1** Installation Dimensions

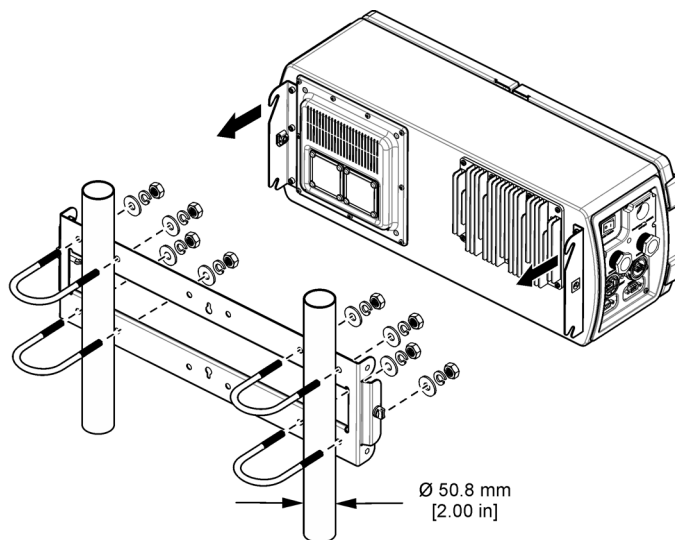


**Figure 3.2** Wall Mount

## Attach the Instrument to Dual Pipes

Refer to [Figure 3.1](#) for dimensions. Refer to [Figure 3.3](#) for installation.

- Attach the analyzer mounting bracket to two instrument pipes that are attached to a common surface. Do not attach the instrument to two instrument pipes that could move independently.
- Use pipes that extend at least 254 mm (10 in.) from the same rigid base.
- Use pipes with a diameter of 50.8 mm (2 in.) or less.
- Use four user-supplied 5/16-inch U-bolts (two for each 2-inch pipe) and eight user-supplied matching nuts. Use U-bolts and nuts that can withstand the process environment.
- Use U-bolts and nuts that do not extend more than 15 mm (0.60 in.) from the inside of the bracket.

**Figure 3.3** Pipe Installation

## Electrical Installation

### Wiring Safety Information



Electrocution hazard. Always remove power to the instrument before making electrical connections.

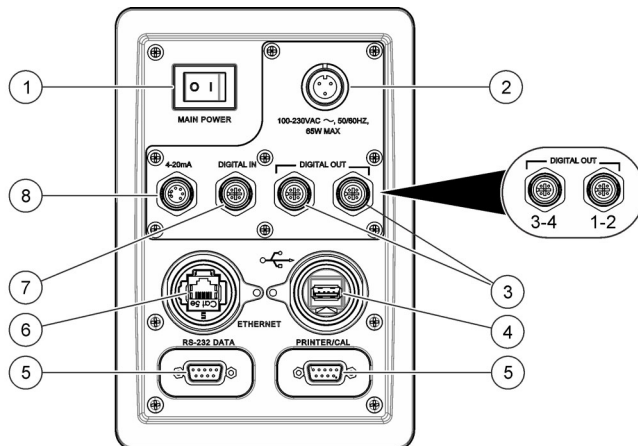
### About Quick-Connect Wiring Connections



Electrocution and fire hazards. For instruments with a power cord, make sure that there is easy access to the local power disconnect.

Figure 3.4 shows the quick-connect connections.

Figure 3.4 Power Supply and Wire Connections



- |                          |                              |
|--------------------------|------------------------------|
| 1. Power switch          | 5. RS232 connections         |
| 2. Power cord connection | 6. Network connection        |
| 3. Digital output        | 7. Digital input             |
| 4. USB port              | 8. 4-20 mA output connection |

### Connect the Power Cord

- 1 Connect the power cord to the instrument. Refer to [Figure 3.4](#), item 2.

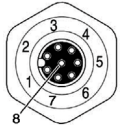


- 2 Tighten the compression fitting by hand.

### Connect the 4–20 mA Output

Table 3.1 shows the terminal designations for the 4–20 mA quick-connect connector. The default parameter represented on each 4–20 mA output is shown in Table 3.1. To change the default parameter, refer to [Configure the Analog Outputs](#).

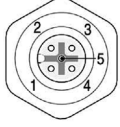
**Table 3.1** 4–20 mA Terminal Designations

Connector	Terminal	Description	Variable	Designation
	1	4–20 mA source output for analog output 1 (+)	TOC from Stream 1 (configurable)	AO1+
	2	4–20 mA sink output for analog output 1 (-)	TOC from Stream 1 (configurable)	AO1-
	3	4–20 mA source output for analog output 2 (+)	Conductivity or resistivity from Stream 1 (configurable)	AO2+
	4	4–20 mA sink output for analog output 2 (-)	Conductivity or resistivity from Stream 1 (configurable)	AO2-
	5	4–20 mA source output for analog output 3 (+)	Temperature from Stream 1 (configurable)	AO3+
	6	4–20 mA sink output for analog output 3 (-)	Temperature from Stream 1 (configurable)	AO3-
	7		—	
	8		—	

### Connect the Discrete Inputs

Table 3.2 shows the discrete input designations for the quick-connect connector.

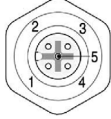
**Table 3.2** Discrete Input Designations

Connector	Terminal	Description	Variable	Designation
	1	Common connection for external source (+)	Common	DI1/2+
	2	Digital input 1 (-)	Start a single TOC analysis	DI1-
	3	Digital input 2 (-)	Stream selection	DI2-
			—	
			—	

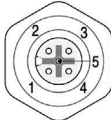
### Connect the Discrete Outputs

The terminal designations for the discrete output quick connections are shown in [Table 3.3](#) and [Table 3.4](#).

**Table 3.3** Discrete Output 1 and 2

Wiring connector 1-2	Terminal	Description	Default value	Designation
	1	Digital output 1 (+)	TOC alarm (configurable)	DO1+
	2	Digital output 2 (+)	Source stream (configurable)	DO2+
	3	Common return (-)	Digital output 1 and 2 common return	DO1/2-
	4		—	
	5		—	

**Table 3.4** Discrete Output 3 and 4

Wiring connector 3-4	Terminal	Description	Default value	Designation
	1	Digital output 3 (+)	Error alarm (configurable)	DO3+
	2	Digital output 4 (+)	Valve state (TOC analysis start, configurable)	DO4+
	3	Common return (-)	Digital output 3 and 4 common return	DO3/4-
	4		—	
	5		—	

## Connect a 40-Column Printer

Connect a printer to the 9-pin D-subminiature serial port as necessary. This RS232 interface communicates at 9600 baud, 8 data bits, 1 stop bit and no parity. A 40-column printer is necessary for the printout report. Refer to [Configure the Printer Settings](#) to change the default printer settings.

If the printer is purchased from the manufacturer of the analyzer, the DIP switches on the printer are set at the factory. If a Seiko Instruments DPU-414 Type II thermal printer is installed, set the DIP switches. Refer to [Set the Printer DIP Switches](#).

### Set the Printer DIP Switches

- 1 Set the printer power switch to OFF.
- 2 Push and hold **ONLINE**, then switch the power switch to ON. Release the button when a printout of the current settings starts.
- 3 Push **ONLINE** again. "DIP SW1" shows on the printout. This is a prompt to change DIP switch 1 (switches 1-8).

- 4** Enter the settings for DIP switch 1 (switches 1–8) in succession. Push **ONLINE** for on. Push **FEED** for off. Refer to [Table 3.5](#), [Table 3.6](#) and [Table 3.7](#).

The ONLINE light comes on to identify an ON entry. The OFFLINE light goes off to identify an OFF entry. Make sure to enter a setting for all eight switches. The setup mode cannot be cancelled after it is started.

- 5** After all eight switches have been set for DIP switch 1, a printout prompt asks whether to continue or repeat the procedure for DIP switches 2 and 3 or save the current settings.

After the settings have been saved, a printout is made and the printer goes back to normal operation. Do not turn the printer off while it is saving settings. Wait until “Dip SW setting complete!” is on the printout before the printer power is set to off.

**Table 3.5** Printer DIP Switch 1 Settings

Switch	Setting	Function
1	Off	Serial input
2	On	High print speed
3	On	Auto loading enabled
4	Off	Auto linefeed disabled
5	On	Enabled setting
6	Off	Print density
7	On	Print density
8	On	Print density

**Table 3.6** Printer DIP Switch 2 Settings

Switch	Setting	Function
1	On	40-column printing
2	On	Backup font enabled
3	On	Normal characters
4	Off	Zero = Slash
5	On	International character set = USA
6	On	International character set = USA
7	On	International character set = USA
8	Off	International character set = USA

**Table 3.7** Printer DIP Switch 3 Settings

Switch	Setting	Function
1	On	8 data bits
2	Off	Parity setting = Yes
3	On	Parity condition = Odd
4	Off	Flow control (X on/X off)
5	Off	9600 baud rate
6	On	9600 baud rate
7	On	9600 baud rate
8	On	9600 baud rate

## Plumbing

---

### Plumb the Instrument



**Chemical exposure hazard. Obey laboratory safety procedures and wear all of the personal protective equipment appropriate to the chemicals that are handled. Refer to the current material safety data sheets (MSDS) for safety protocols.**

Refer to [Figure 3.5](#) and the steps in this procedure to plumb the instrument.

#### User-supplied items:

- Wrench, 7/16-in.
- Isolation valve
- Tubing, ¼-in. OD polypropylene, PFA or 316 stainless steel for inlet and outlet

- 1 Install the isolation valve on the process pipe. Open and close the isolation valve several times to let water into the system to remove debris.
- 2 Push the tube from the isolation valve into the WATER IN port until it stops. Do not crimp or bend the tubing.

- 
- 3** Tighten the compression nut on the WATER IN port by hand. Make a mark on the compression nut and tube for reference.

**NOTE** For the dual stream model, do step 2 and 3 for the second WATER IN port.

---

- 4** Tighten the compression nut another  $1\frac{1}{4}$  turns.
- 

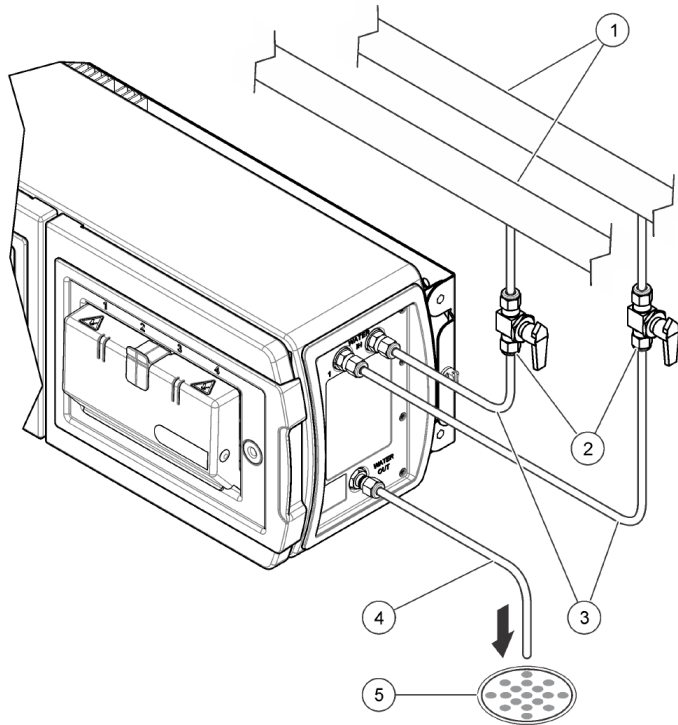
- 5** Push one end of a 10-ft tube into the WATER OUT port until it stops. Do not crimp or bend the tubing.
- 

- 6** Tighten the compression nut on the water outlet side by hand. Make a mark on the compression nut and tube for reference.
- 

- 7** Tighten the compression nut another  $1\frac{1}{4}$  turns.
- 

- 8** Do a leak test:
- a.** Slowly open the isolation valve to let water into the instrument.
  - b.** Open and close the valve several times to pulse water through the connections.
  - c.** Examine the compression fittings for leaks.
  - d.** If necessary, slowly tighten the compression fittings to stop leaks.
-

**Figure 3.5** Plumb the Instrument



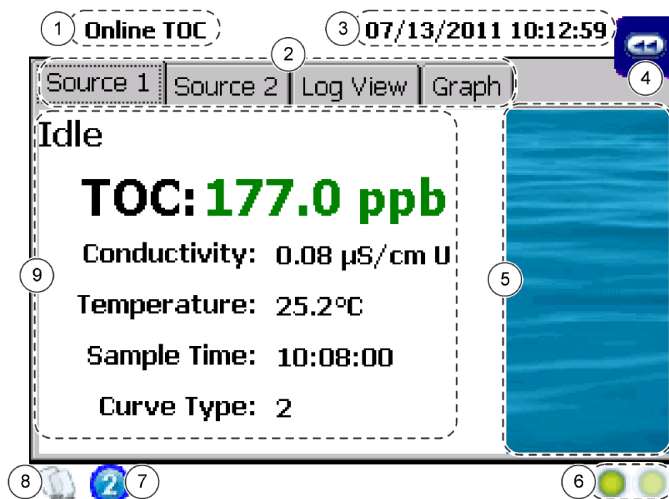
- |                                       |                          |
|---------------------------------------|--------------------------|
| 1. Process pipe                       | 4. Drain tubing, ¼-in.OD |
| 2. Isolation valve, customer-supplied | 5. Drain                 |
| 3. Water in tubing, ¼-in. OD          |                          |

# CHAPTER 4

## User Interface and Navigation

After startup, the user interface shows the home screen. Refer to [Figure 4.1](#).

**Figure 4.1** Home Screen



- |                             |                       |
|-----------------------------|-----------------------|
| 1. Run mode                 | 6. Lamp status        |
| 2. View tabs                | 7. Stream ID          |
| 3. Current date and time    | 8. Bottle mode access |
| 4. Sliding toolbar          | 9. Data section       |
| 5. Animated process graphic |                       |

## Sliding Toolbar






Use the sliding toolbar to open the main functions of the instrument. [Table 4.1](#) shows the options on the sliding toolbar.

To open the sliding toolbar, select the << icon in the top left of the measurement screen.

**Table 4.1** Sliding Toolbar Options

Icon	Function	Description
	Run mode	Set or change the operation mode and self-clean mode
	Setup	Show the Setup menu.

**Table 4.1** Sliding Toolbar Options

Icon	Function	Description
	Bottle mode	General—Run standards, grab sample, bottle flush, and unload bottles.
		RFID model—Run standards, grab sample, bottle flush, unload bottles, and excursion mode.
	Alarm	Review and acknowledge alarms.
	Diagnostics	General—Monitor lamp use and test, change or replace lamps.
		Diagnostic tests—Test the pump, 4–20 mA output, digital I/O, plumbing, RS232, RFID, fan and touchscreen calibration.
		Calibration—See the calibration dates.
		Diagnostic Tests - Printer Test
	Data review	Review, print or export data.
	Sign on or off	If password security is enabled, users must use a password to make operation changes. Log off to prevent access to system changes.  <b>NOTE</b> If a user is signed on remotely, the user cannot be signed off locally. If a user is signed on locally, the user cannot be signed off by a remote user.

## Setup Menu

Table 4.2 shows the options on the setup menu.

**Table 4.2** Setup Menu Options

Icon	Description
TOC	Change the settings for the TOC operating mode. Refer to <a href="#">TOC Operating Mode Configuration</a> .
System	Change the system settings for the analyzer (instrument name, language, time, measurement units, sounds, backlight, and automatic exporting). Refer to <a href="#">System Configuration</a> .
Alarms	Change the settings for the digital output alarms. Refer to <a href="#">Configure the Digital Output Alarms</a> .
Analogs	Change the settings for the analog outputs. Refer to <a href="#">Configure the Analog Outputs</a> .
Printer	Change the printer settings. Refer to <a href="#">Configure the Printer Settings</a> .
Security	Enable or disable security and/or data logging of exported data. Set password expiration and lock screen. Add, change or delete user accounts. Show the audit trail. Refer to <a href="#">Security Configuration</a> .
Bottles	Change the auto acceptance and test completion criteria for bottle mode operations. Refer to <a href="#">Bottle Mode Configuration</a> .



**Table 4.2** Setup Menu Options

Icon	Description
Password	Change the password of the user that is logged in. This icon is only enabled when security is enabled.
Stream	Change the source stream or set the source stream to toggle between Stream 1 and Stream 2. Give Stream 1 and Stream 2 a different name (default = Stream 1 and Stream 2).
Factory	Shows the factory settings which can only be changed by factory authorized users. Push the <b>X</b> icon to show the factory settings (e.g., model number, serial number and factory icon calibration date) or copy the oxidation buffers (3 maximum) to a USB flash drive.



## Connect to Power

---

After plumbing and wiring are complete, connect the instrument to power. For the location of the power switch and power cord, refer to [Figure 3.4](#).

- 1 Connect the power cord to a power outlet with a safety ground.
  - 2 Toggle the power switch to on.
  - 3 Make sure that the startup screen shows on the display.
- 

## Set the Sample Flow Rate

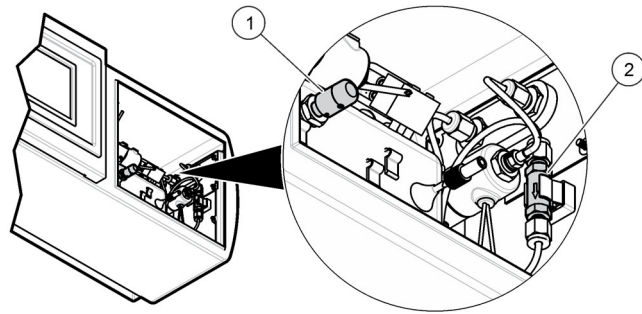
---

Adjust the flow rate before initial operation. Refer to [Specifications](#) for sample requirements. For hot water applications, a flow rate of 60 mL/minute is recommended.

**NOTE** The flow rate changes with water pressure, so it may not be possible to get the same flow rate for both sample streams.

- 1 Push << to show the sliding menu.
  - 2 Push **RUN MODE**.
  - 3 Select **Standby**.  
**NOTE** In Standby, water continues to flow through the instrument.
  - 4 Use a graduated cylinder to measure the amount of water that drains from the instrument in 15 seconds.
  - 5 Use the flow control valve to adjust the flow rate. Refer to [Figure 5.1](#).
-

**Figure 5.1** Flow Control Valve



1. Flow control valve

2. Water filter

## Select the Run Mode

---

- 1 Push << to show the sliding menu.
- 2 Push **RUN MODE**.
- 3 Select an operation. Refer to [Run Modes](#).

Option	Description
Online TOC	Monitor TOC continuously in process
Conductivity	Monitor conductivity continuously in process
Standby	Put the instrument in standby mode (valve open)
Offline	Put the instrument in offline mode (valve closed)
TOC manual sample	Manual TOC measurement for online sample
Self-clean	Configure and start a clean cycle

- 4 Push **ENTER**.
- 

## Calibration

---



**Chemical exposure hazard. Obey laboratory safety procedures and wear all of the personal protective equipment appropriate to the chemicals that are handled. Refer to the current material safety data sheets (MSDS) for safety protocols.**

### TOC Calibration

Calibrate the instrument for TOC measurements with default settings or with custom settings. Use default settings with packaged standards kits that use RFID tags on the bottles. Use custom settings for less replicates or less bottles.

- 
- 1 Make sure that the TOC standards are at room temperature.

---

  - 2 Push << to show the sliding menu.

---

  - 3 Push **BOTTLE MODE**, then **RUN STANDARDS**.

---

  - 4 Push **TOC CALIBRATION**.

---

  - 5 Select default or custom settings.

---

  - 6 Obey the screen prompts to set the number of repetitions and confirm the sucrose standard values.  
**NOTE** To save the new settings as the default, push **SAVE AS DEFAULT**.

---

  - 7 Install the standards in the order shown on the screen. If the bottle bay door closes too soon, push **UNLOCK** to open the door.

---

  - 8 Push **START**.

---

  - 9 When the calibration is complete, the results are shown. If a printer is attached, the report can be sent to a printer. Select the necessary action to complete the calibration.
    - Push **CHECK** to accept the calibration and to remove the bottles. This option will not show if the Autoaccept setting is enabled.
    - Push **CANCEL** to repeat the calibration and discard the results.
    - Push **EXPORT** to send the data to the supplied USB flash drive.
- 

## Conductivity Calibration

Use the optional calibration resistor for this procedure. [Figure 6.1](#) shows the location of the calibration resistor.

- 
- 1 Make sure that the conductivity standards are at room temperature.

---

  - 2 Push << to show the sliding menu.

---

**3** Push **BOTTLE MODE**, then **RUN STANDARDS**.

---

**4** Push **CONDUCTIVITY CALIBRATION**.

---

**5** Obey the screen prompts.

---

**6** Install the standards in the order shown on the screen. If the bottle bay door closes too soon, push **UNLOCK** to open the door.

---

**7** Push **START**. Install the resistor when the screen prompt shows.

**NOTE** When the calibration is complete, the results show on the screen. If a printer is attached, the report prints automatically.

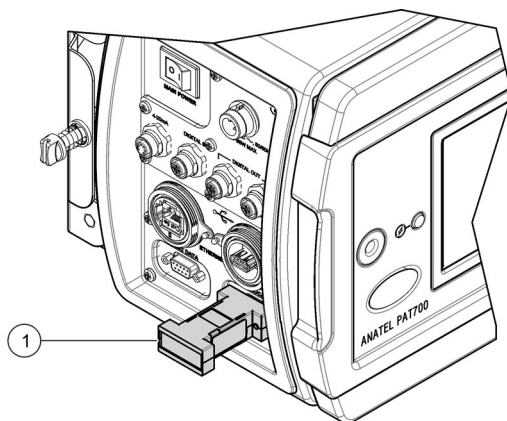
---

**8** Select the necessary action to complete the calibration.

- Push **CHECK** to accept the calibration and to remove the bottles. This option will not show if the Autoaccept setting is enabled.
- Push **CANCEL** to repeat the calibration and discard the results.
- Push **EXPORT** to send the data to the supplied USB flash drive.

---

**Figure 6.1** Calibration Resistor



1. Calibration resistor (optional)

## Do a System Suitability Test

---

A system suitability test examines analyzer measurements according to the guidelines established in USP Method <643> using 500 ppb sucrose and 500 ppb 1,4-benzoquinone standards.

---

**1** Make sure that the system suitability test standards are at room temperature.

---

**2** Push << to show the sliding menu.

---

**3** Push **BOTTLE MODE**, then **RUN STANDARDS**.

---

**4** Push **SYSTEM SUITABILITY**.

---

**5** Install the standards in the order shown on the screen.

**NOTE** If the bottle bay door closes too soon, push **UNLOCK** to open the door.

---

**6** Close the bottle bay door, then push the forward icon.

If bottles have been properly loaded and the RFID tags can be read, the review test setup dialog box shows. If not, enter the bottle information as prompted.

---

**7** Push **START**.

Three samples are drawn from each bottle. After all the repetitions are complete, the analyzer repeats the process for the rest of the bottles.

Once all the bottles have been analyzed, the analyzer compares the average reading of the sucrose standard to the average reading of the 1,4 benzoquinone. If the two values are within  $\pm 15\%$  of each other, the test passes. The analyzer then shows the test summary dialog box. The formulas that follow are used to calculate the response efficiency.

$$r_e = 100 \times (SR \div LR)$$

Where:

SR = suitability response of the analyzer defined as  $(r_{ss} - r_w)$

LR = limit response of the analyzer defined as  $(r_s - r_w)$ .

$r_e$  = response efficiency of the PAT700

$r_w$  = average TOC response for the blank

$r_s$  = average TOC response for the sucrose standard

$r_{ss}$  = average TOC response for the benzoquinone standard



- 
- 8** When the suitability test is completed, the results are shown. If a printer is attached, the report prints automatically. Select the necessary action to complete the validation.
- Push **CHECK** to accept the system suitability test and to remove the bottles. This option will not show if the Autoaccept setting is enabled.
  - Push **CANCEL** to repeat the system suitability test and discard the results.
  - Push **EXPORT** to send the data to the supplied USB flash drive.
- 

## Measure a Grab Sample

---

Use the grab sample test to measure samples taken from other locations. Grab samples do not need bottles with RFID tags.

---

- 1** Push << to show the sliding menu.
- 

- 2** Select **BOTTLE MODE**, then **GRAB SAMPLE**.
- 

- 3** Obey the screen prompts to enter the values.

**NOTE** To save the new settings as the default, push **SAVE AS DEFAULT**.

---

- 4** Install the standards in the order shown. If the bottle bay door closes too soon, push **UNLOCK** to open the door.
- 

- 5** Set the volume of each sample bottle.
- 

- 6** Set an ID for each bottle.
- 

- 7** Push **START**.

**NOTE** When the measurement is complete, the results show on the screen. If a printer is attached, the report prints automatically.

---

- 8** Select the necessary action to complete the calibration.

- Push **CHECK** to accept the measurement and remove the bottles. This option does not show if the autoaccept setting is enabled.
- Push **CANCEL** to repeat the measurement and discard the results.

- Push **EXPORT** to send the data to the supplied USB flash drive.

## Manage Measurement Data

Measurement data can be reviewed on the instrument, printed, exported and filtered.

- 1 Push << to show the sliding menu.
- 2 Select **DATA REVIEW**. The data review window shows. Icon command options show on the bottom of the screen.

## Set the Data Filter

Data can be filtered by test type, date range or special ranges.

- 1 Push << to open the sliding menu.
- 2 Select **DATA REVIEW**, then **FILTER**.
- 3 Select all of the data types that apply. All types are selected by default.
- 4 Select time range or special range. Special range options sets the data to sort first by type, then by time. The time range option sets the data to sort based on the specified date range.

Option	Description
Last accepted	Includes only the last accepted tests for the selected data types
Last done	Includes only the last completed tests for the selected data types
Last five	Includes only the last five completed tests for the selected data types

## Export or Print Data

- 1 Push << to show the sliding menu.

---

**2** Select **DATA REVIEW**.

---

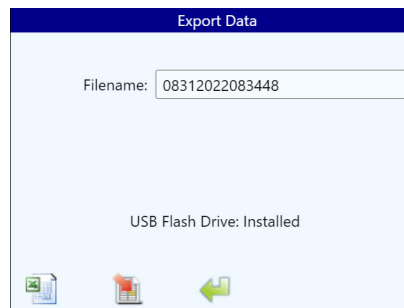
**3** To print:

- Push the **Printer** icon to send data to an attached printer.

---

**4** To export:

- Push the **Export** icon to enter the export screen.



- Check **FTP** to send data as formatted text or PDF to a networked server using FTP.
  - Check **USB Drive** to send data as formatted text or PDF to the supplied USB flash drive.
-



## Select the Source Stream

---

Set the source stream to Stream 1, Stream 2 or to toggle between Stream 1 and Stream 2.

**NOTE** As an alternative to the steps that follow, push the Stream ID icon on the home screen, then go to step 5.

---

**1** Push << to show the sliding menu.

---

**2** Push **SETUP**.

---

**3** Push **STREAM**.

---

**4** Select the Stream tab.

---

**5** Select an option.

Option	Description
Source Stream 1	Only the sample from Stream 1 will be analyzed.
Source Stream 2	Only the sample from Stream 2 will be analyzed.
Source Stream Toggle	The analyzer does an analysis cycle for Stream 1 and then an analysis cycle for Stream 2.

---

**6** To change the default name for Stream 1 and/or Stream 2 (default = Stream 1 and Stream 2), select the Naming tab.

---

## TOC Operating Mode Configuration

---

### Configure the General Settings

---

**1** Push << to show the sliding menu.

2 Push the **SETUP** icon.

3 Push **TOC**.

4 Select the General tab.

5 Select an option.

Option	Description
Flush Time	Set the amount of time the cell is flushed before a TOC analysis is started (hh:mm:ss). Options: 00:00:00 to 23:59:59 (default = 00:01:00)
Cycle Time	Set the minimum amount of time between automatic TOC analyses. Any value less than the actual elapsed time causes the next analysis to start immediately (hh:mm:ss). Options: 00:00:00 to 99:59:59 (default = 00:00:00)
Use pump	Enable the sample pump for online sampling (default = disabled). Do not enable the sample pump on a pressurized system or pump damage may occur.
Bypass flow during analysis	Enable bypass flow. When disabled, the bypass flow valve stays closed. When enabled, sample water flows continuously through the analyzer (bypasses the analysis cell) during TOC analysis. The bypass valve is open when the sample is captured and closed when the analysis is complete.
Bypass Toggle Time	When bypass flow is enabled, sets the amount of time that water flows from a sample stream before the analyzer switches to the other sample stream. Lets both sample streams flow during TOC analysis.
Switch Lamps when Marginal	Enable the analyzer to switch to the other UV lamp when the UV lamp diagnostics sense a marginal level of UV intensity on the operating UV lamp.

## Configure the Flow During Idle Mode

Select the state the analyzer will enter while it waits for the next analysis (cycle) to start. The analyzer will only enter idle mode if the cycle time is more than the combined flush time and oxidation time.

1 Push << to show the sliding menu.

2 Push the **SETUP** icon.

3 Push **TOC**.

4 Select the Idle tab.

5 Select an option.

Option	Description
Without conductivity	The bypass valve opens during idle mode. There is continuous flow through the bypass loop. No conductivity is reported.
With conductivity	The sample valve opens during idle mode. There is continuous flow through the sample cell. Conductivity of the water is reported.
None	The analyzer sample valve closes during idle mode. There is no flow through the sample cell.

## Configure Digital Control

Enable the digital inputs and set the states for digital input control as necessary.

The two digital inputs are optically isolated. The inputs are rated for 5–30 VDC, 2–15 mA. Terminals 4 and 5 of the discrete input terminal supply a 12 VDC output that can be used to drive each digital input. Both digital input 1 and digital input 2 share a common positive power connection. In the default setting:

- **Digital Input 1**—A high to low (power supplied for at least 500 milliseconds) transition on digital Input 1 stops the current operation and immediately starts a single TOC analysis. The analysis goes to completion regardless of whether subsequent trigger values are received. When the analysis is complete, the instrument goes back to the previous run mode.
- **Digital Input 2**— When digital input 2 is high (no power supplied), the analyzer is set to sample from Stream 1. When digital input 2 is low (power supplied across pins 1 and 3), the analyzer is set to sample from Stream 2.

1 Push << to show the sliding menu.

2 Push the **SETUP** icon.

3 Push **TOC**.

4 Select the Digital Control tab.

5 Select an option.

Option	Description
Control with digital inputs	Enable the two digital inputs to control the TOC analysis and run mode (default = disabled). When enabled, the normal operating modes shown on the Run Mode window do not apply.  <b>NOTE</b> When a TOC analysis is started with digital input 1, the analyzer ignores all other commands through the digital inputs.
Invert Digital Inputs	Invert the default state for control of the digital inputs.  <b>Digital Input 1</b> —When power is removed across pins 1 and 2 for at least 500 milliseconds, the analyzer stops the current operation and does a single TOC analysis.  <b>Digital Input 2</b> —When power is supplied across pins 1 and 3 (low state), the source stream analyzed is Stream 1. When power is not supplied across pins 1 and 3 (high state), the source stream analyzed is Stream 2.
Make TOC analog output persistent	Hold the last reported value at the output when the stream selection is changed from Stream 1 to Stream 2 or from Stream 2 to Stream 1.
Invert Digital Outputs	Invert the default state of each digital output (1–4). For the default state of each digital output, refer to <a href="#">Table 7.1</a> .

## Enable the Stabilization Process

When the analyzer switches to do an online TOC analysis after it operates in continuous flow modes (such as conductivity mode or standby) for extend periods of time, a stabilization process should be done. The stabilization process can decrease the number of TOC analysis cycles necessary to give stable results.

During the stabilization process, water is trapped in the sample cell and the UV lamp is set to on to thermally stabilize and clean the sample cell.

- 1 Push << to show the sliding menu.
- 2 Push the **SETUP** icon.
- 3 Push **TOC**.
- 4 Select the Stabilization tab.
- 5 Select an option.



Option	Description
Stabilize cell prior to analyzing	Enable automatic stabilization of the sample cell before a reportable TOC analysis is done.
Time between TOC analyses	Set the minimum elapsed time between TOC analysis before the automatic stabilization process is activated (hh:mm:ss). Options: 00:00:01 to 23:59:59 (default = 02:00:00)
Stabilization time	Set the amount of time to do the stabilization process (hh:mm:ss). Options: 00:00:01 to 23:59:59 (default = 00:10:00)

### Set the TOC Offset

Use the TOC offset feature to make the TOC output between two instruments the same and better than the  $\pm 5\%$  specification. The TOC offset value is applied to the reported TOC analysis result.

- 1 Push << to show the sliding menu.
- 2 Push the **SETUP** icon.
- 3 Push **TOC**.
- 4 Select the Offset tab.
- 5 Enter the TOC offset. Options: +5.0 and -5.0.

## System Configuration

### Set the Analyzer Name, Location and Language

- 1 Push << to show the sliding menu.
- 2 Push the **SETUP** icon.
- 3 Push **SYSTEM**.

4 Select the General tab.

5 Select an option.

Option	Description
Instrument Name	Enter the name that will be used for the analyzer by the system. Options: 1 to 13 alphanumeric or symbol characters (default = PAT700 + the serial number)  <b>NOTE</b> The system will reboot when the instrument name is changed.
Location	Enter the location of the instrument.
Language	Set the language for all interfaces (default = English). For Japanese and Chinese translations, this option is not available. The applicable language will be installed at the factory.  <b>NOTE</b> A change to the language setting changes the operating system setting in the registry. When the system is rebooted, the new setting is used.

## Set the Date, Time and Units

Set the date, time, temperature units and conductivity units that show on the display.

1 Push << to show the sliding menu.

2 Push the **SETUP** icon.

3 Push **SYSTEM**.

4 Select the Display tab.

5 Select an option.

Option	Description
Date/Time	Push <b>Set Time</b> . Use the arrow keys to enter the date and time.
Time Format	Set the time format (default = 24-Hour).
Temperature display	Set the temperature units (default = Deg. C).
Conductivity display	Set the conductivity units (default = $\mu\text{S}/\text{cm}$ U = uncompensated conductivity).

## Configure the Alarm Sounds

Select the alarm sound for each alarm type.

- 1 Push << to show the sliding menu.
- 2 Push the **SETUP** icon.
- 3 Push **SYSTEM**.
- 4 Select the Sounds tab.
- 5 Select a sound for each alarm type. Push the speaker icon to hear the selected sound.
- 6 Push the volume slider to set the speaker volume.

## Configure the Backlight Settings

- 1 Push << to open the sliding menu.
- 2 Push the **SETUP** icon.
- 3 Push **SYSTEM**.
- 4 Select the Backlight tab.
- 5 Configure the backlight options.

Option	Description
Automatically turn off backlight	Have the backlight switch off automatically after a period of inactivity.
Turn off after	Select the number of minutes of inactivity before the backlight switches off. Options: 15 or 30 seconds and 1, 2, 5, 10, 15, 30 minutes.

- 
- 6 To adjust the brightness of the backlight, push the brightness slider.
- 

## Configure the Digital Output Alarms

---

Assign output functionality for each digital output as necessary. Refer to [Table 7.1](#). To invert the digital outputs, refer to [Configure Digital Control](#).

**NOTE** The TOC alarm can be assigned to multiple digital outputs (1–4) at the same time to set a multi-level alarm on the TOC result.

- 
- 1 Push << to show the sliding menu.
- 

- 2 Push the **SETUP** icon.
- 

- 3 Push **ALARMS**.
- 

- 4 Assign the output functionality for each digital output. Refer to [Table 7.1](#).

**NOTE** Conductivity alarm, Error state and Valve state can only be assigned to one digital output at a time.

- 
- 5 Select the checkbox to enable the alarm, if present.
- 

- 6 For TOC alarm, select the upper TOC limit for the alarm. Options: 1 to 2500 (default = 500). This value applies only to online TOC analysis, not to bottle or grab sample analysis.
-

**Table 7.1** Digital Output – Default States

Alarm type	Description
TOC alarm	High state—The TOC level is below the selected upper limit. Low state—The TOC level is above the selected upper limit. When enabled, any online TOC reading that is more than the alarm upper limit triggers a TOC alarm.
Conductivity alarm	High state—The conductivity level is below the conductivity limit. Low state—The conductivity level is above the conductivity limit. The actual (uncompensated) conductivity limits are in accordance with the specifications set forth in the method “<645> Water Conductivity” of the USP 25–NF 20 (January 2002). Refer to <a href="#">Conductivity Alarm Limit</a> . For proper operation of the conductivity alarm, uncompensated conductivity must be selected under the Display tab in the System settings.
Source stream	High state—Stream 2 Low state—Stream 1
Error state	High state—No error conditions are present. Low state—An error condition is present.
Valve state (TOC analysis start)	High state—The inlet sample valve is open. Low state—The inlet sample valve is closed.

## Conductivity Alarm Limit

The actual sample water temperature is rounded down to the nearest 5 degrees to set the conductivity limit. This makes sure that any potential excursions are identified early. For example, if the measured water temperature is 24.5 °C, the 20 °C limit is applied and an alarm is triggered if the conductivity is more than 1.1 µS/cm U.

To make sure of an agreement between all data outputs, the TOC, conductivity and temperature values are all rounded to have the same accuracy as the analyzer for alarm limit checking, display, printouts and any digital outputs.

**Table 7.2** Conductivity Alarm Limit

Temperature (°C)	Uncompensated conductivity (µS/cm)	Temperature (°C)	Uncompensated conductivity (µS/cm)
0	0.6	55	2.1
5	0.8	60	2.2
10	0.9	65	2.4
15	1.0	70	2.5
20	1.1	75	2.7
25	1.3	80	2.7
30	1.4	85	2.7
35	1.5	90	2.7

**Table 7.2** Conductivity Alarm Limit

Temperature (°C)	Uncompensated conductivity (µS/cm)	Temperature (°C)	Uncompensated conductivity (µS/cm)
40	1.7	95	2.9
45	1.8	100	3.1
50	1.9		

## Configure the Network Settings

- 1 Push << to show the sliding menu.

---

- 2 Push the **SETUP** icon.

---

- 3 Push **Network**.

---

- 4 Select the **General** tab.

---

- 5 Select an option.

Option	Description
Static TCP/IP Address	Set the TCP/IP address for the analyzer. Options: 0 to 255 for each octet (default = 192.168.0.105).
Static Subnet Mask	Set the subnet mask for the analyzer. Options: 0 to 255 for each octet (default = 192.168.0.1).
Static Gateway	Set the default gateway for the analyzer. Options: 0 to 255 for each octet (default = blank).
DNS Server	Set the DNS server address for the analyzer. Options: 0 to 255 for each octet (default = blank).
WINS Server	Set the WINS server address for the analyzer. Options: 0 to 255 for each octet (default = blank).
DHCP	Enable DHCP. When selected, the TCP/IP address, subnet mask and default gateway entries are disabled (default = enabled). When DHCP is selected, all of the text fields are disabled.

## Configure the FTP Function

With firmware V3.6.16 onwards, the PAT700 can be configured to transmit data via Ethernet (as text or PDF) to an FTP server. The PAT700 can connect to servers that use FTP or FTPS (Explicit TLS/SSL).

---

**1** For the user account that will be used in the particle counter, give file access on the FTP server: Read, Write and Delete.

---

**2** For the user account that will be used in the particle counter, give directory access on the FTP server: Create, Delete, List and Add Subdirectories.

**NOTE** The Create, Delete and Add Subdirectories rights are only necessary if the PAT700 will be configured to make subdirectories. These rights are not necessary when the PAT700 is configured to use the existing directories.

---

**3** From the side bar, select the **Setup** icon.

---

**4** From the setup screen, select the **Network** icon.

---

**5** From the **General** tab, verify that the IP address is configured correctly. Refer to [Configure the Network Settings](#).

---

**6** Navigate to the **FTP Setup** tab.

---

**7** Check **FTP Enabled**.

---

**8** Enter the Host name or IP address of the FTP server.

---

**9** Enter the port number in **Port** (default 21).

---

**10** Select either **FTP** or **FTPS** (secure FTP through TLS/SSL).

---

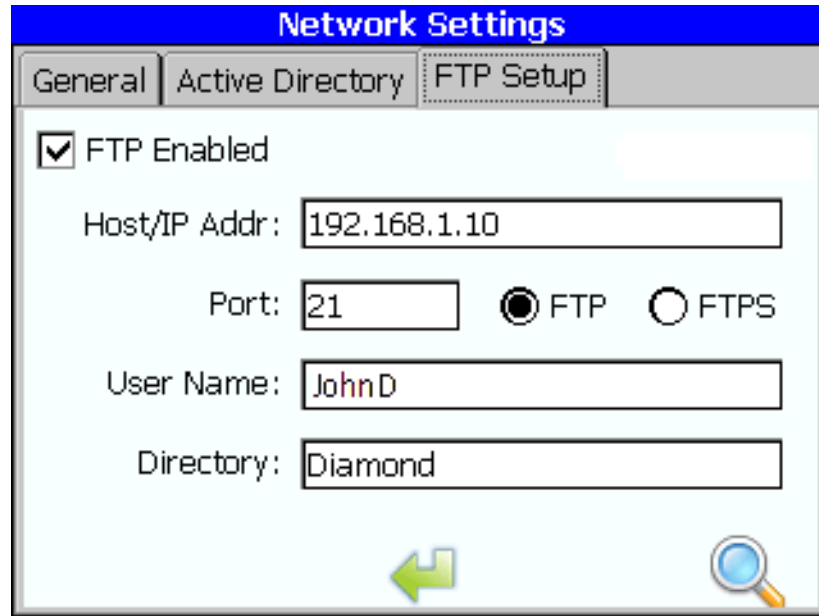
**11** Select the User Name field.

- When prompted, enter a username with adequate write privileges to the FTP location.
- When prompted, enter the user's password.

**NOTE** This password will not be displayed.

12 Enter the subdirectory on the FTP server to use. If left blank, a period (.) will be inserted automatically to accommodate the FTP protocol, and files will be placed in the root.

13 Press the **FTP Test Connection** icon.



The screenshot shows a dialog box titled "Network Settings" with three tabs: "General", "Active Directory", and "FTP Setup". The "FTP Setup" tab is selected. The dialog contains the following fields and options:

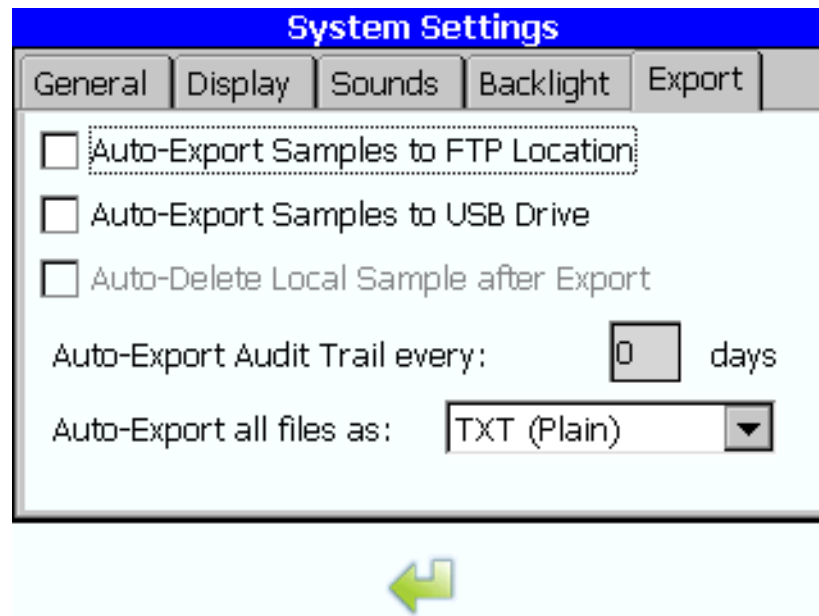
- FTP Enabled
- Host/IP Addr:
- Port:   FTP  FTPS
- User Name:
- Directory:

At the bottom of the dialog, there is a green arrow icon pointing left and a magnifying glass icon.

**NOTE** Review the console to verify proper configuration. If successfully configured, the last line will state **SUCCESS**.



- 14** For firmware version V3.6.16 onwards, the PAT700 can be configured to automatically export data via FTP over Ethernet at pre-programmed times. Under 'System Settings' select the 'Export' tab to configure this feature.



## Configure Active Directory Settings

**Active Directory**—With firmware V3.6.16 onwards, this option allows users signed in with Administrator rights to add groups from their Active Directory server and define that group's security role (operator, maintenance, admin). All Active Directory users who are in that Active Directory group will be granted that level of access.

- 1** Push << to open the sliding menu.
- 2** Push the **SETUP** icon.
- 3** Push **Network Settings**.
- 4** Select the **Active Directory** tab.
- 5** Enter the Active Directory Server Address.

- 
- 6 Select the **Add Group** icon to add an existing group from your Active Directory server.
- 

## Configure the Analog Outputs

---

Set the parameter (TOC, conductivity or temperature), upper limit and lower limit for each analog output. Set the value at the analog outputs when an error occurs or when in bottle mode.

- 1 Push << to show the sliding menu.
- 2 Push the **SETUP** icon.
- 3 Push **ANALOGS**.
- 4 Select the General tab.
- 5 Set the value at the analog outputs that will be present when an error occurs. Do one:
  - Enter the analog value (2–22 mA) that will be present at all the analog outputs when an error is active.
  - Select the checkbox so the outputs represent the last value measured.
- 6 Set the value at the analog outputs when the analyzer is in bottle mode. Do one:
  - Enter the analog value (2–22 mA) that will be present at all the analog outputs when in bottle mode.
  - Select the checkbox so the outputs represent the sample result.
- 7 Set the parameter, upper limit and lower limit for each analog output (Channel 1–3). Select the applicable Channel tab.
  - a. In the Output field, select the parameter.
  - b. In the Zero Scale field, enter the lower limit parameter value that will be represented as 4 mA at the analog output. Options: TOC = 0 to 1999, Conductivity = 0 to 19, Temperature = 0 to 99

- c. In the Full Scale field, enter the upper limit parameter value that will be represented as 20 mA at the analog output. Options: TOC = 1 to 2000, Conductivity = 1 to 20, Temperature = 1 to 100

**NOTE** The most typical configuration is Channel 1 = TOC from Stream 1 and Channel 2 = TOC from Stream 2.

## Configure the Printer Settings

Configure the analysis result printing and the printing frequency for the online TOC mode and conductivity mode.

1 Push << to show the sliding menu.

2 Push the **SETUP** icon.

3 Push **PRINTER**.

4 Select the General tab.

5 Select the type of printer.

6 Select the TOC tab.

7 Select an option.

Option	Description
Disabled	Disable the printing of online TOC readings.
Continuous	Enable continuous printing. A TOC printout occurs at the end of each analysis cycle.

8 Select the Conductivity tab.

9 Select an option.

Option	Description
Disabled	Disable the printing of online conductivity readings.
Timed	Enable continuous printing. A conductivity printout occurs at the end of each interval. Enter an interval in the Interval field. Options: 1 minute (default) to 24 hours
Percent Change	Enable a printout to occur only when the change in conductivity between successive analyses is more than the value in the Limit field. Enter a value in the Limit field. Options: 1 (default) to 100%

## Security Configuration

### Enable Security and Data Logging

1 Push << to show the sliding menu.

2 Push the **SETUP** icon.

3 Push **SECURITY**.

4 Select the General tab.

5 Select an option.

Option	Description
Enable Security	Enable security (default = disabled). Login is necessary before changes are made. Only the administrator may access the security settings.  <b>NOTE</b> When not selected, no login is necessary and the audit trail is disabled.
Enable Data Logging	Enable data logging (default = enabled). All data (maximum of 5000 records) is automatically kept in the internal data buffer.

6 To set all the settings back to the factory defaults, push **Restore Factory Defaults**.

## Set Password Expiration and Automatic Log Off

1 Push << to show the sliding menu.

2 Push the **SETUP** icon.

3 Push **SECURITY**.

4 Select the Settings tab.

5 Select an option.

Option	Description
Passwords expire in	Set the number of days before a password must be changed. Options: 30 to 365 days (default = 60)
Remember last	Set the number of passwords that are kept in memory to prevent the use of an old password. Options: 0 to 5 (default = 3)

## Add, Delete or Change Users

A maximum of 10 operator users can be added. Only operator users may be added or deleted. The administrator and factory users cannot be deleted.

There are five types of users:

**Guest**—This is the day-to-day user. This user does not have to log on. This user may access all areas that the day-to-day user requires and view TOC and Conductivity results but cannot change any settings or start any operations. This user cannot carry out Calibrations or System Suitability tests. Guests have no access to the security settings dialog box.

**Operator**—This user is typically the calibration/service technician. This user must log on and any actions they take will be recorded in the Audit Trail (providing Security is turned on - see [Security Configuration](#)). This user has full access to most dialog boxes, including the Bottle Mode used for Calibration and System Suitability tests. Operators have no access to the security settings dialog box and read-only access to the factory settings and the bottle mode settings.

**Administrator**—Has full access to most dialog boxes. This user must log on and any actions they take will be recorded in the Audit Trail (providing Security is turned on - see [Security Configuration](#)). In addition to the rights assigned to the Maintenance user this user has access to add users and assign user rights for other users. This user also has rights to configure all default settings on the PAT700. This user has read-only access to the factory dialog box. The default administrator entry has a user

name of "Administrator", a user ID of "Admin" and a default password of "123456". The user is forced to create a new password at first log on.

**Factory**—Has full access to all dialog boxes.

**NOTE** Push the **Print** icon to print the user settings for all the users except the administrator and factory users.

---

**1** Push << to show the sliding menu.

---

**2** Push the **SETUP** icon.

---

**3** Push **SECURITY**.

---

**4** Select the Users tab. A list of the operator users that have been added shows. The administrator and factory users are not shown.

---

**5** To add a user:

- a. Push the + icon.
- b. Enter the full name of the user (5 to 20 alphanumeric or symbol characters and must be unique).
- c. In the ID field, enter a unique user identifier (5 to 15 alphanumeric or symbol characters).
- d. Enter a password for the user (5 to 15 alphanumeric or symbol characters). Passwords are case sensitive.
- e. Enter the password for the user again to confirm.
- f. To make the user change their password at the next logon, select Change Password.

**NOTE** Password changes are recorded in the audit trail and password history list. New and old passwords are not recorded in the audit trail.

---

**6** To change a user:

- a. Select a user.
- b. Push the triangle icon.
- c. Edit the fields as necessary.

**NOTE** To exit and not save, push the "x" icon.

---

**7** To delete a user:

- a. Select a user.
- b. Push the "-" icon.

- c. Push **Yes** to confirm.
- 

## About Backdoor Passwords

If administrators or factory personnel forget their passwords, they may get temporary access with a backdoor password supplied by factory service. Upon successful sign on, the analyzer prompts the user to change the password.

Contact technical support to get a backdoor password for the analyzer. To get the password, the factory asks for the serial number and current date shown on the analyzer. Have this information ready.

## Show the Audit Trail

Only administrator and factory users can see the audit trail. Any additions, changes or deletions to the analyzer configuration are recorded in the audit trail with the:

- Keyword ("added", "modified" or "deleted")
- Information affected
- Old value if applicable
- New value if applicable
- Full name of the user that did the operation
- Date and time of the change

System events such as logging in and exporting data are also recorded in the audit log.

---

- 1 Push << to show the sliding menu.
- 

- 2 Push the **SETUP** icon.
- 

- 3 Push **SECURITY**.
- 

- 4 Select the Audit trail tab. The audit trail shows. The audit trail shows the filtered audit trail data.
  - **Daily header**—Shown once per day before the first entry and at the change from one day to the next.
  - **Entry header**—Shown at the start of each audit trail entry. It includes the time of the entry in long format (hh:mm:ss) and the name of the person associated with the entry. If the analyzer time is configured for 24-hour format, the AM/PM entry is blank.
  - **Audit trail actions**—shown after the entry header. There are four types of entries possible for this section (data added, data modified, data deleted or user action).

Data added—the keyword “Added” shows before the item name. The next line contains the keyword “New Value:” and then the value name.

Data modified—the keyword “Modified” shows before by one space and the item name. The next line contains the keyword “Old Value:” and then the value name. The next line contains the keyword “New Value:” and then the value name.

Data deleted—the keyword “Deleted” shows before two spaces and the item name. The next line contains the keyword “Old Value:” and then the value name.

- 
- 5 To send the audit trail data to the printer, push **PRINTER**.

---

  - 6 To send the audit trail data to the USB flash drive, push **EXPORT**. The audit trail sends the entire audit trail in formatted clear text with a checksum to make sure that there is data integrity.

---

  - 7 To delete the audit trail, push **CLEAR DATA LOG**.

---

  - 8 To filter the audit trail, push the Filter icon.
- 

## Bottle Mode Configuration

---

### Configure the TOC Calibration Settings

- 
- 1 Push << to show the sliding menu.

---

  - 2 Push the **SETUP** icon.

---

  - 3 Push **BOTTLES**.

---

  - 4 Select the TOC Calibration tab.



5 Select an option.

Option	Description
User must manually accept results after test is complete	The results of the TOC calibration are not used until they are manually accepted.
Return to online mode	The analyzer goes back to the online mode after the TOC calibration. When not selected, the analyzer stays at the bottle mode dialog box. All valves are closed. The pump is off. The lamp is off.  <b>NOTE</b> This option is only available when "User must accept results after test is complete" is selected.
Auto accept results and return online	The Slope Limit and R2 Limit options that follow are enabled. If the calibration is accepted, the new calibration factors are used.
Slope Limit <=	Set the limit of the slope for the calibration to pass. Options: 1 to 15% (default = 15%)  <b>NOTE</b> This option is only available when "Auto accept results and return online" is selected.
R2 Limit >=	Set the limit for the determination coefficient. Options: 0.9000 to 0.9999 (default = 0.9900)  <b>NOTE</b> This option is only available when "Auto accept results and return online" is selected.
Display 'as Received' reports	Enable 'as Received' reports to be shown in the calibration results.

## Configure the Conductivity Calibration Settings

- 1 Push << to show the sliding menu.
- 2 Push the **SETUP** icon.
- 3 Push **BOTTLES**.
- 4 Select the Conductivity Calibration tab.

5 Select an option.

Option	Description
User must manually accept results after test is complete	The results of the conductivity calibration are not used until they are manually accepted.
Return to online mode	The analyzer goes back to the online mode after the conductivity calibration. When not selected, the analyzer stays at the bottle mode dialog box. All valves are closed. The pump is off. The lamp is off.  <b>NOTE</b> This option is only available when "User must accept results after test is complete" is selected.
Auto accept results and return online	The Slope Limit options that come next are enabled. If the calibration is accepted, the new calibration factors are used.
Slope Limit from previous cal <=	Set the percent difference between the resulting gain factor and the current value. Options: 1 to 5% (default = 5%)  <b>NOTE</b> This option is only available when "Auto accept results and return online" is selected.
Slope Limit from factory cal <=	Set the percent difference between the resulting gain factor and the factory value. Options: 1 to 10% (default = 10%)  <b>NOTE</b> This option is only available when "Auto accept results and return online" is selected.
Use Calibration Resistor	The calibration check resistor is used during the conductivity calibration process.

## Set the Analyzer to Return to Online Mode

Set the analyzer to return to the online mode after TOC validation, the System suitability test and/or the analysis of one/multiple grab sample(s), or stay at the bottle mode dialog box (default).

- 1 Push << to show the sliding menu.
- 2 Push the **SETUP** icon.
- 3 Push **BOTTLES**.
- 4 Select the TOC Validation, System Suitability or Grab Sample tab.

- 
- 5 To have the analyzer return to online mode after the operation is completed, select the Return to online mode checkbox.  
When not selected, the analyzer stays at the bottle mode dialog box after the operation. All valves are closed. The pump is off. The lamp is off.
- 

## Bottle Mode Operation

---

### Validate the TOC Calibration

Validate the TOC calibration with the default settings or custom settings. A TOC validation can be a single-point analysis or multi-point analysis. Use the default settings with the packaged standards kits that use RFID tags on the bottles. Use the custom settings to add bottles or to use less replicates.

The instrument response for the validation standard must have a deviation of less than 15% of the calibrated response to be accepted.

- 
- 1 Make sure that the TOC standards are at room temperature.
  - 2 Push << to show the sliding menu.
  - 3 Push **BOTTLE MODE**, then **RUN STANDARDS**.
  - 4 Push **TOC VALIDATION**.
  - 5 Select the default or custom settings. The default setting is a blank bottle and one standard of 500 ppb sucrose. To do a multi-point validation, select the custom settings and enter the necessary configuration. At least one bottle must be selected.
  - 6 Obey the screen prompts to set the number of repetitions and confirm the sucrose standard values.  
**NOTE** To save the new settings as the default, push **SAVE AS DEFAULT**.
  - 7 Install the standards in the order shown on the screen.  
**NOTE** If the bottle bay door closes too soon, push **UNLOCK** to open the door.

- 
- 8** Close the bottle bay door, then push the forward icon.  
If bottles have been correctly loaded and the RFID tags can be read, the review test setup dialog box shows. If not, enter the bottle information as prompted.
- 
- 9** Push **START**.  
The dialog box shows the current status of the test and a lists of the results of each repetition and bottle as it is being read.
- 
- 10** When the validation is complete, the results are shown. If a printer is attached, the report prints automatically. Select the necessary action to complete the validation.
- Push **CHECK** to accept the TOC validation and to remove the bottles. This option will not show if the Autoaccept setting is enabled.
  - Push **CANCEL** to repeat the TOC validation test.
  - Push **EXPORT** to send the data to the supplied USB flash drive.
- 

## Get an Excursion Sample

Use excursion mode to withdraw sample from the current source stream to fill two 65 mL RFID tagged bottles when a TOC alarm, conductivity alarm or specific alarm conditions occurs. An excursion sample can also be implemented manually.

**NOTE** Excursion mode does not operate without RFID tagged excursion bottles. A minimum flow rate of 160 mL/minute is necessary for excursion capture.

**Items needed:** two RFID tagged excursion bottles

- 
- 1** Push << to show the sliding menu.
- 
- 2** Push **BOTTLE MODE**, then **EXCURSION MODE**.
- 
- 3** Install the RFID tagged bottles as shown on the screen.  
**NOTE** If the bottle bay door closes too soon, push **UNLOCK** to open the door.
- 
- 4** Close the bottle bay door, then push the forward icon.
- 
- 5** Enter the TOC limit in the Excursion mode setup screen. Options: 1 to 2000 ppb (default = 500 ppb)

---

**6** To immediately fill the excursion bottles, push **START**.

---

**7** Push **DONE** to go to the home screen.

When an excursion condition occurs, the analyzer collects a sample. When both bottles are filled, the instrument automatically does a confirmation analysis on the contents of the first bottle. This offline analysis is then used to validate the online result.

When the analysis of the contents of the first bottle is completed, the TOC results are reported and if the results (TOC or Cond > limit) are the same, the message "Excursion is valid" is reported. If the results are not the same (TOC or Cond < limit), the message "Excursion not valid" is reported.

The water sample in the second bottle is available for lab analysis to identify the cause of the water system excursion.

---

## Flush the Sample Bottle Lines

---

**1** Push << to show the sliding menu.

---

**2** Push **BOTTLE MODE**, then **BOTTLE FLUSH**.

---

**3** Install bottles of pure water as shown on the screen.

**NOTE** If the bottle bay door closes too soon, push **UNLOCK** to open the door.

---


**4** Close the bottle bay door, then push the forward icon.

The analyzer starts the flushing cycle and will identify on the display which bottle line is in the cleaning process.


---





 **Multiple hazards. Only qualified personnel must conduct the tasks described in this section of the document.**



 **Electrocution hazard. Remove power from the instrument before doing maintenance or service activities.**

## Maintenance Schedule

---

Table 8.1 shows the recommended schedule of maintenance tasks. Facility requirements and operating conditions may increase the frequency of some tasks.

**Table 8.1** Maintenance Schedule

Task	12 months <sup>a</sup>	As necessary
Clean the Instrument		X
Clean Leaks and Spills		X
Replace the water filter <sup>b</sup>	X	
Replace the UV lamps <sup>b</sup>	X	
Replace a Fuse		X

- a. Only if **Switch Lamps when Marginal** is selected in General Settings. See [TOC Operating Mode Configuration](#)
- b. Refer to the instructions supplied with the replacement part.

## Clean the Instrument

---

Clean the exterior of the instrument with a moist cloth and a mild soap solution.

## Clean Leaks and Spills

---



**Chemical exposure hazard. Dispose of chemicals and wastes in accordance with local, regional and national regulations.**



**Personal injury hazard. The sample line contains water under high water pressure that can burn skin if hot. Qualified personnel must remove the water pressure and wear personal protective equipment during this procedure.**

**IMPORTANT** Tighten a new ferrule 1¼ turns the first time it is tightened. Then, only tighten the ferrule 1/8 turn to make a connection. Do not tighten the fittings more as this may cause damage to the fittings or ferrules and cause leaks.

If a leak occurs in the tubing, the sample water will drain from small holes in the bottom of the enclosure.

For leaks caused by a valve, worn tubes or other parts, send the instrument to the manufacturer for service. Refer to [Send the Instrument for Service](#).

- 
- 1 Put on protective eye wear.

---

  - 2 Set the power switch to off.

---

  - 3 Disconnect the sample supply. Let the sample cool if hot.

---

  - 4 Open the tubing enclosure.

---

  - 5 Use sample flow that is not hot to find the leak.

---

  - 6 Tighten fittings as necessary. Look for additional leaks and repair if possible.

---

  - 7 After the leaks are repaired, remove excess water that is on the inside and underside of the enclosure with paper towels. Let the enclosure dry completely with the door open.



- 
- 8 Use a towel or mop to remove spills around the analyzer.

---

  - 9 Close the enclosure door. Set the power switch to on.

---

  - 10 Do a plumbing test to make sure that the analyzer can operate without leaks. Refer to [Do a Plumbing Test](#).
- 

## Replace a Fuse

---



**Fire hazard. Use the same type and current rating to replace fuses.**

Fuse failure may be an indication that the instrument has a problem that requires service. [Figure 8.1](#) shows the fuse location.

**Item to collect:** 1.25 A, 250 V EN60127 type T fuse

- 
- 1 Toggle the power switch to off. Disconnect the instrument from the power outlet.

---

  - 2 Use the supplied tool to open the display-side door.

---

  - 3 Use a flat-blade screwdriver to remove the fuse holder.

---

  - 4 Replace the fuse with a fuse of the same type and rating.

---

  - 5 Use the flat-blade screwdriver to install the fuse holder.

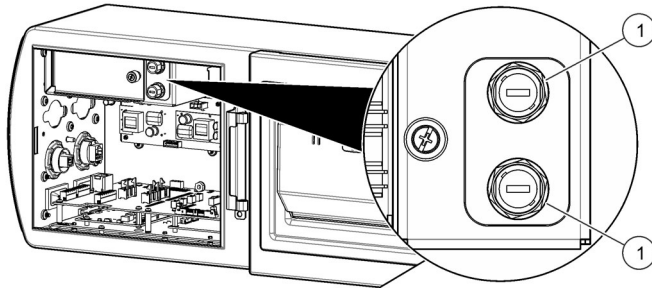
---

  - 6 Close the display-side door with the supplied tool. Make sure that the door is tightly closed to keep the enclosure rating and the safety protections.

---

  - 7 Connect the instrument to the power outlet. Toggle the power switch to on.
-

Figure 8.1 Fuse Location



1. Fuse (2x)

## Drain the Instrument

---

To prepare the instrument for storage or shipment, remove all water from the instrument. Water left in the instrument may freeze, expand and cause instrument damage. Water in the measurement cell may contain contaminants that will cause damage to instrument components.

To drain all water from the instrument:

- 1 Remove the instrument from service.
- 2 Disconnect the instrument from the water system.
- 3 Set the power switch to on.
- 4 Push << to show the sliding menu.
- 5 Select **Diagnostics > Tests > Plumbing Test**.
- 6 From the drop-down menu, select Flow through cell with pump.
- 7 Let the test continue until all of the water has drained from the instrument.
- 8 When the water flow stops, push the green arrow to stop the plumbing test.

## Send the Instrument for Service

---



**Chemical exposure hazard. Dispose of chemicals and wastes in accordance with local, regional and national regulations.**

- 
- 1** Drain the instrument. Refer to [Drain the Instrument](#).
  - 2** Clean the instrument fully.
  - 3** Get a return authorization from the manufacturer. Make sure that the return authorization number is on the shipping label.
-

**Maintenance**

Send the Instrument for Service

The analyzer incorporates extended diagnostic and reporting to inform the user about the nature of a problem.

Alarm codes, with user-initiated diagnostic tests, serve to isolate the source of the problem. The analyzer constantly monitors its operation and measurement values for alarm conditions.

Alarm conditions include error alarms, critical error alarms, warning alarms and measurement alarms.

## Alarms

---

### Alarm Indication

The analyzer has two basic operational modes: online and bottle. The online TOC and conductivity are the two primary online modes. In online TOC and conductivity modes, the measurement screen shows an animation that identifies the general state of water flow through the analyzer.

In online TOC, conductivity, or manual TOC modes, the animation area is also an alarm condition indicator. When an alarm occurs in an online mode:

- The animation area flashes red.
- The value of the variable that has caused the alarm becomes red.
- The alarm sound\* is heard if enabled.
- The alarm condition is recorded to the data log and audit trail.
- The alarm icon is enabled.
- Error, critical error or warning: The digital output that represents the error state identifies an error condition. Refer to [Configure the Digital Output Alarms](#).
- Error or critical error: The three analog outputs identify an error condition (2 mA or 22 mA). Refer to [Configure the Analog Outputs](#).

After an alarm is acknowledged:

- The animation area shows steady red.
- The alarm sound is not heard.
- Once a full cycle has occurred without any errors, the error is removed and the normal animation shows. The digital output will no longer show an error state and the analog outputs represent the new valid result.

---

\* Each type of alarm (stop, warning, alarm) has a different sound. If multiple alarms occur, only the highest-level alarm is heard.

- If on the next cycle the same or a new error occurs, the animation area again flashes red and must be acknowledged.
- As long as alarms are present in the alarm log, the alarm log is available.

## Accept or Remove an Alarm

When a warning or an error that is not critical occurs, the animation area of the measurement screen flashes red.

- 1 Push << to show the sliding menu.
- 2 Select **ALARMS**. The Alarm Acknowledge screen opens.
  - Push **ACCEPT ALARMS** (bell with green checkmark) to acknowledge the alarm.
  - Push **DELETE ALARMS** (bell with a red X) to delete all alarms in the list.
- 3 Push **ENTER** to return to the measurement screen. If the error condition still exists but has been accepted, the animation area shows steady red.

## Error Codes

[Table 9.1](#) shows the error codes that occur any time one of the non-critical subsystems fail or a failure occurs from which the analyzer tries to recover.

When an error occurs, the animation area flashes red to identify when an error condition is present. In addition, the digital output that represents the error condition and the three analog outputs (2 or 22 mA) change their state to identify when an error condition is present. Refer to [Alarm Indication](#).

When the error condition is removed, the analyzer attempts to recover and continue to operate. Once a valid TOC measurement is completed, the analog outputs once again represent the measured values.

**Table 9.1** Error Codes

Code	Message	Description
SC027	FalseConductivity	The measured conductivity is less than 0.
SC029	BadTocConvert	The temperature/conductivity is out of bounds for TOC conversion.
SC035	LowOxidationRate	The TOC is too low (out of range).
SC036	NegativeTOC	Negative TOC (out of range). Organic acids may be present.
SC037	LowTemperature	The temperature is out of range low.
SC038	HighTemperature	The temperature is out of range high.

**Table 9.1** Error Codes

Code	Message	Description
SC039	LowResistance	The resistivity is out of range low.
SC040	HighResistance	The resistivity is out of range high.
SC112	UnableTo-StartPrinterModule	The analyzer cannot start the printer module.
SC113	UnableTo-StartRs232Module	The analyzer cannot start the RS-232 module.
SC116	UnableTo-ReadDataLog	The analyzer cannot read the data log.
SC117	UnableTo-WriteToDataLog	The analyzer cannot write to the data log.
SC128	UvLampMonitorFailed	The UV lamp monitor has failed.
SC151	LampExtinct	The current lamp has failed. Replace the lamp.
SC163	UnableTo-StopCurrentOperation	The analyzer cannot stop its current operation.
SC164	UnknownError	The analyzer has experienced an unknown error.
SC167	WatchDogIoCard	The I/O card has stopped responding.
SC168	WatchDogTocAlgorithm	The TOC algorithm has stopped responding.
SC169	WatchDogPrinter	The printer has stopped responding.
SC170	WatchDogRs232	The RS-232 module has stopped responding.
SC177	Exception	An exception was thrown.
SC188	TOCOverLimit	The TOC measurement is more than the instrument range.

### Critical Error Codes

In a critical error condition, the instrument cannot function. The error shows as a full-screen flashing message. The digital output that represents the error condition and the three analog outputs (2 or 22 mA) change their state to identify when an error condition is present. Refer to [Alarm Indication](#).

Operation stops until the error condition is corrected. Touch the screen interface to accept the alarm and see more information. Refer to [Table 9.2](#).

**Table 9.2** Critical Error Codes

Code	Message	Description
SC110	UnableTo-StartIoModule	The analyzer cannot start the IO module.
SC111	UnableTo-StartTocModule	The analyzer cannot start the IO module.
SC114	UnableTo-StartEthernetModule	The analyzer cannot start the Ethernet module.
SC152	LampUnableToSwitch	The analyzer cannot switch from one lamp to the other.
SC173	RangeTable-FailedToLoad	The RangeTable.txt file could not be loaded.
SC174	InstrumentTemperature	The ambient temperature is more than the instrument specifications. Decrease the instrument and environmental temperature.
SC175	BothLampsBad	Both UV lamps have failed. Replace both lamps.

**Table 9.2** Critical Error Codes

Code	Message	Description
SC176	NoCond-TempReadings	The analyzer cannot measure conductivity and temperature. Restart the analyzer.
SC179	HardwareInitializationFailure	An error occurred during the hardware initialization.

### Warning Codes

When a warning condition is present, a warning indicator (flashing red rectangle on the display) shows on the display to identify that a warning message is pending in the alarm log. The digital output that represents an error condition changes its state to identify when a warning condition is present. The three analog outputs do not identify when a warning condition is present. Refer to [Alarm Indication](#).

Operation may continue when a warning condition is present. Refer to [Table 9.3](#).

**Table 9.3** Warning Codes

Code	Message	Description
SC100–SC103	IncorrectBottle-LoadedinPositionX	Incorrect bottle detected in position X. The analyzer cannot do the bottle test operation. Examine and change the bottle as necessary.
SC104–SC107	NotEnough-FluidinBottleX	There is not enough fluid in bottle to complete the operation. The analyzer aborts operation and returns to its normal operating mode.
SC108	UnableTo-ReadSettings	Some or all of the settings could not be read from the settings file.
SC109	UnableTo-WritetoSettings	The analyzer cannot write to the settings file.
SC118	UnableTo-ChangeLanguageSettings	The analyzer cannot change the language settings.
SC119	UnableTo-ReadLanguageSettings	The analyzer cannot read the language settings.
SC120	UnableTo-ChangeEthernetSettings	The analyzer cannot change the Ethernet settings.
SC121	UnableTo-ReadEthernetSettings	The analyzer cannot read the Ethernet settings.
SC122	UnableTo-PrintSystemSettings	The analyzer cannot print the system settings.
SC125	UnableTo-StartLampTest	The analyzer cannot start the lamp test.
SC126	UnableTo-StopLampTest	The analyzer cannot stop the lamp test.
SC127	UvLampLifeExceeded	The maximum lamp hours of usage have been exceeded or the UV Detect™ output is below the acceptable limit. The lamp has been set to a status of marginal. Replace the lamp.
SC129	UnableTo-ReadInformationFromBottle	The analyzer cannot read the information from the bottle.
SC130	UnableTo-WriteInformationToBottle	The analyzer cannot write the information to the bottle.
SC132	UnableTo-StartPumpTest	The analyzer cannot start the pump test.



**Table 9.3** Warning Codes

Code	Message	Description
SC133	UnableTo-StopPumpTest	The analyzer cannot stop the pump test.
SC134	UnableTo-CalibratePump	The analyzer cannot calibrate the pump.
SC135	UnableTo-ExportDataLog	The analyzer cannot export the data log.
SC136	UnableTo-ExportAuditTrail	The analyzer cannot export the audit trail.
SC137	UnableTo-AddUser	The analyzer cannot add a user.
SC138	UnableTo-EditUser	The analyzer cannot edit a user.
SC139	UnableTo-DeleteUser	The analyzer cannot delete a user.
SC141	UnableTo-AcknowledgeAlarms	The analyzer cannot acknowledge alarm.
SC142	UnableTo-SilenceAlarms	The analyzer cannot delete alarms.
SC143	UnableTo-StartSelfClean	The analyzer cannot start the self-clean.
SC144	UnableTo-StopSelfClean	The analyzer cannot stop the self-clean.
SC145	UnableTo-StartOnlineManualSample	The analyzer cannot start the online manual sample.
SC147	UnableTo-RestoreFactoryDefaults	The analyzer cannot restore the factory defaults.
SC150	UnableTo-PrintDataLog	The analyzer cannot print the data log.
SC153–SC156	BottleXMarkedAsUsed	The bottle installed in location is marked as used. Replace the bottle with the correct standard.
SC160	ExcursionBottle4NotEmpty	The excursion bottle is not empty. Replace the excursion bottle with an empty bottle.
SC165	LampSwitch	One lamp is weak or has failed. Replace the lamp.
SC172	RougeDetected	One or more of the 500 ppb standards took longer than expected to oxidize. Clean the cell.
SC178	ExcursionCaptured	An excursion sample was captured in an excursion bottle. Remove the sample from the analyzer.
SC180	ConductivityMeterAlarm	The analyzer has not passed the conductivity meter test.
SC181	BottleTestCancelled	The bottle test was cancelled by the user. Start the test again.
SC182–SC185	BottleXExpired	The bottle installed in the location has expired. Replace the bottle with the correct standard.
SC186	BottleTestCanceled-ExpiredStandard	The bottle test was canceled because there is an expired standard bottle in the bottle bay.
SC189	IncorrectRFID	The standards bottle has a incompatible RFID tag.
SC192	ExcursionNotConfirmed	The excursion is not confirmed.

### Measurement Alarm Codes

Measurement alarms occur when TOC or conductivity levels in the process water are more than the set limits. Refer to [Table 9.4](#).

The digital outputs that identify a TOC alarm or conductivity alarm change their state when a measurement alarm is present. Refer to [Configure the Digital Output Alarms](#). The three analog outputs continue to represent the last measured value when a measurement alarm is present.

**Table 9.4** Measurement Alarm Conditions

Code	Message	Description
SC161	TOCAlarm	The measured TOC is more than the user-defined TOC level.
SC162	ConductivityAlarm	The measured conductivity is more than the USP645 conductivity level.

## Diagnostics

---

### Review the Data Log Usage and Firmware Version

- 1 Push << to show the sliding menu.
- 2 Push **DIAGNOSTICS**, then select the General Tab.  
The data log percent usage and the firmware version show.

### Review the UV Lamp Information

See the lamp status and the number of operational hours until the next lamp replacement.

- 1 Push << to show the sliding menu.
- 2 Push **DIAGNOSTICS**, then select the General Tab.

Option	Description
Status	The color indicator shows the lamp status. Green=normal operation, yellow=marginal operation, red=lamp fault
Hours left	Shows the hours of useful lamp life until the next replacement.

## Do a Lamp Test

- 1 Push << to show the sliding menu.
- 2 Push **DIAGNOSTICS**, then select the General tab.
- 3 Push **LAMP TEST**.
- 4 Obey the screen prompts to start the lamp test.

**NOTE** Push the **X** icon at any time to stop the test.

## Change to the other UV Lamp

- 1 Push << to show the sliding menu.
- 2 Push **DIAGNOSTICS**.
- 3 Push **SWITCH LAMPS**. The lamp status light changes to the new selection.

## Select a Diagnostic Test

- 1 Push << to show the sliding menu.
- 2 Push **DIAGNOSTICS**, then select the Tests tab.
- 3 Select the necessary test. Obey the screen prompts to start the test.

**NOTE** Push **X** at any time to stop the test.

## Validate the RS232 Connection

Use the RS232 test icon to test serial communication from the serial port. The printer port is used as a return port. The analyzer sends serial data out one serial port and reads the data on the other. If the read data matches the sent data, the test passes.

- 
- 1 Push << to show the sliding menu.

---

  - 2 Push **DIAGNOSTICS**, then select the Tests tab.

---

  - 3 Push **RS-232 TEST**.

---

  - 4 Disconnect the printer and the RS232 serial connections.

---

  - 5 Connect a serial cable between the serial ports of the analyzer (from one serial port to the other).

---

  - 6 Push **START**.

## Validate the Digital I/O Communication

Use the digital I/O test icon to test digital I/O communication. The test toggles the state on each digital output, then reads the state on each of the digital inputs. The results are shown on the screen.

- 
- 1 Push << to show the sliding menu.

---

  - 2 Push **DIAGNOSTICS**, then select the Tests tab.

---

  - 3 Push **DIGITAL I/O TEST**.

---

  - 4 Connect the digital inputs of the analyzer to a system that can send a digital signal.

---

  - 5 Configure one digital input with a high signal and the other with a low signal.

---

  - 6 Connect the digital outputs to a system that can read digital signals.

---

**7** Push **START**.

---

### Validate the 4-20 mA Output

Use the 4–20 mA output test icon to test the signal on the 4–20 mA outputs.

---

**1** Push << to show the sliding menu.

---

**2** Push **DIAGNOSTICS**, then select the Tests tab.

---

**3** Push **4-20 mA OUTPUT TEST**.

---

**4** Connect a digital multi-meter to one of the 4–20 mA outputs.

---

**5** Push **START** for the output that is connected to the multi-meter.  
A 4 mA signal and then a 20 mA signal are sent from the output for 3 seconds.

---

### Do a Printer Test

Use the printer test to send a test printout to the printer. Before the test, make sure that the analyzer is correctly connected to the printer.

---

**1** Push << to show the sliding menu.

---

**2** Push **DIAGNOSTICS**, then select the Tests tab.

---

**3** Push **PRINTER TEST**.

---

### Do a Plumbing Test

Use the plumbing test to test the various analyzer plumbing systems.

---

**1** Push << to show the sliding menu.

**2** Push **DIAGNOSTICS**, then select the Tests tab.

**3** Push **PLUMBING TEST**.

If a current analysis is being done, the analysis is stopped.

**4** Select an option.

Option	Description
None	Set the pump to off. Close all the valves.
Bypass	Open only the bypass valve
Flow through cell	Open only the cell valve
Flow through cell with pump	Open the cell valve and the pump valve. Set the pump to on.
Flow through cell from Stream 2	Open only the cell valve
Flow through cell with pump from Stream 2	Open the cell valve and the pump valve. Set the pump to on.
Sample from bottle	Open the selected bottle valve and the pump valve. Set the pump to on.
Back flush through bottle	Open the selected bottle valve and the cell valve
Back flush through bottle from Stream 2	Open the selected bottle valve and the cell valve

**5** Push **LOAD BOTTLES**.

**6** Select the bottles to load, then push the forward icon.

**7** Install the standards in the order shown on the screen.

**NOTE** If the bottle bay door closes too soon, push **UNLOCK** to open the door.

**8** Close the bottle bay door.

**9** Push **START**.

**10** Select the applicable test.

**11** When the test is completed, push **UNLOAD BOTTLES**.

- 
- 12** If a test is selected immediately, select **YES** to install a bottle as necessary. Enter the volume of the bottle. Push the forward icon to start the test.
- 

### Validate the Pump Operation

Use the pump test icon to test and/or calibrate the pumps.

---

- 1** Push << to show the sliding menu.

---

- 2** Push **DIAGNOSTICS**, then select the Tests tab.

---

- 3** Push **PUMP TEST**.

---

- 4** Put a 50-mL graduated cylinder at the water outlet of the analyzer. Do not use tubing.

---

- 5** Make sure that a bottle is installed in position 2 to enable the pump to be primed.

---

- 6** Select an option.

Option	Description
Calibrate Pump	Calibrate the pump.
Start/Stop Pump	Start or stop the pump. <b>Start Pump</b> —Open the pump valve and the grab sample bottle valve, then set the pump to on. The pump stays on until Stop Pump is pushed. <b>Stop Pump</b> —Set the pump to off and close both valves.
Prime Pump	Open the pump valve and the grab sample valve, then set the pump to on. The pump operates long enough to prime. Then, the pump switches off and both valves close.
Load Bottle	Install bottles in the bottle bay.
Unload Bottle	Remove bottles from the bottle bay.

---

- 7** Push **START**.  
If Calibrate Pump was selected, the analyzer pumps water for 30 seconds.

---

- 8** For pump calibration, enter the volume pumped as measured in the graduated cylinder. The test results give the:
  - **Test Time**— Always 30 seconds

- **Expected Results**—The calculated amount of water that should be measured during the test. The formula is:  $V = \text{Flow rate} \div \text{Test time}$ , where Flow Rate = The target flow rate of the pump as entered in the Actual Results text box.
- **Actual Results**—The actual amount of water measured during the test.

---

9 Push the previous icon to save the calibration results.

---

### Do an RFID Test

Use the RFID test to test the RFID reader system.

---

1 Push << to show the sliding menu.

---

2 Push **DIAGNOSTICS**, then select the Tests tab.

---

3 Push **RFID TEST**.

---

4 Install four standards bottles equipped with RFID tags in the bottle bay. The bottle can be new or used standards bottles.

---

5 Push **START**.

The system automatically senses those locations where RFID tags are present.

---

6 To cause a test failure, push the unlock icon during the test to open the bottle bay door. The system will return a failed test because the bottles are no longer positioned properly with the door open.

---

### Do a Fan Test

Use the fan test to test the analyzer fans. The analyzer contains an internal online heat exchanger that operates to maintain proper water temperature to the analysis cell. Two fans cool the heat exchanger.

---

1 Push << to show the sliding menu.

---

2 Push **DIAGNOSTICS**, then select the Tests tab.



---

**3** Push **FAN TEST**.

---

**4** Push the fan icon to set the fans to on and off.

---

### Calibrate the Display

If the touch screen display does not allow an accurate item selection, calibrate the display.

---

**1** Push << to show the sliding menu.

---

**2** Push **DIAGNOSTICS**, then select the Tests tab.

---

**3** Push **SCREEN CALIBRATION**.

---

**4** Obey the screen prompts to calibrate.

---

### See the Calibration Dates

---

**1** Push << to show the sliding menu.

---

**2** Push **DIAGNOSTICS**, then select the Calibration Dates tab. The screen shows the last completed calibration dates for TOC, conductivity and the system suitability test.

---

## Technical Support

---

Technical support engineers can provide high quality advice and recommendations for applications, product operation, measurement specifications, hardware and software, factory and customer site training.

Any questionable problems should be referred to the manufacturer. Supply the information that follows in any correspondence:

- The serial number of the instrument
- Sample resistivity and temperature
- Current and historical TOC data
- Current and historical alarm codes
- A setup printout
- Process conductivity or resistivity and temperature
- Current and historical calibration, validation and system suitability results
- Any other significant changes in operating conditions

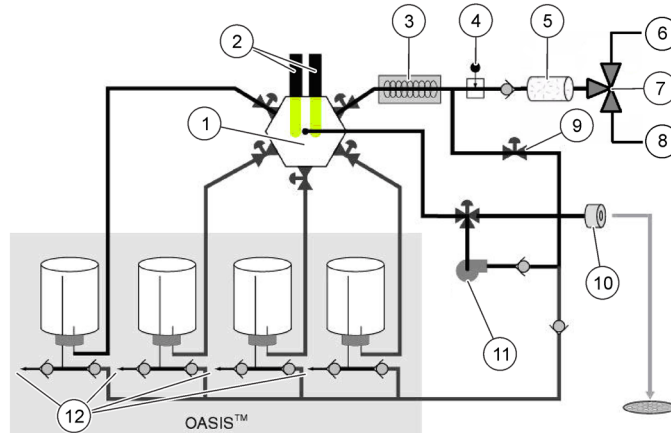
If existing problems warrant equipment return, contact the manufacturer or a sales representative immediately.

## Theory of Operation

The analyzer enables TOC analysis for pure and ultra-pure water processing. The analyzer oxidizes a water sample to find the TOC in the sample. The analyzer traps a water sample in the analysis cell, exposes the sample to ultraviolet (UV) light to oxidize a sample of water (photolysis) and monitors changes in temperature and conductivity until the sample has completely oxidized. Once full oxidation has occurred, the analyzer reports TOC.

Conductivity (in  $\mu\text{S}/\text{cm}$ ) or resistivity (in  $\text{M}\Omega\text{-cm}$ )—unadjusted for temperature or corrected to  $25^\circ$ —and sample temperature are measured and shown along with the oxidation curve type and TOC trend. The analyzer includes an integral inline filter, flow control valve and heat exchanger to make sure that the proper water flow rate and temperature are accurate for TOC analysis. An internal pump is available for sampling water from a supply with no pressure and to deliver standards to the analysis cell from the Onboard Automated Standards Introduction System (OASIS™). Refer to [Figure A.1](#).

**Figure A.1** PAT700 Theory of Operation



- |                      |                         |                     |
|----------------------|-------------------------|---------------------|
| 1. Cell              | 5. Filter               | 9. Bypass valve     |
| 2. Dual UV lamps     | 6. Inlet 1              | 10. To drain outlet |
| 3. Heat exchanger    | 7. 3-way solenoid valve | 11. Pump            |
| 4. Flow needle valve | 8. Inlet 2              | 12. Vent            |

OASIS™ (onboard automated standards introduction system) simplifies analyzer performance tests with standards bottles tagged with Radio Frequency Identification (RFID) technology, which is a registered radio frequency device. The RFID system transmits data wirelessly with radio waves and operates over a very short distance to prevent interference with other wireless communications.

The RFID system communicates with tags and reader/writers. In the analyzer, the tag is attached to the bottom of the standards bottles used in calibrations (conductivity and TOC), validations, system suitability tests and excursion mode. The tag has a microchip attached to a radio antenna connected to a substrate. The microchip keeps data about the standard contained in the bottle.

The OASIS system has four RFID reader/writers permanently attached inside the analyzer that align with the bottle RFID tags when the bottles are fully loaded in the analyzer. The reader/writer retrieves data from the tags. The tag keeps data about the identity of the standard, the concentration of the standards, expiration date and other pertinent data. The reader/writer receives data from the tag and sends the information digitally to the processor.

The RFID system can read and write to the tags attached to the standards bottle. This enables the analyzer to write data to the bottles that shows the bottle has been used and also supplies data for the exclusive excursion sampling feature.

The system operates without any user intervention and operates automatically when bottle tests are done. The system powers on and off to read and write data only when necessary. The RFID labels on the standards bottles contain the data necessary for each standard, the labels must not be removed from the bottle. Without the label, the reader/writer has no data to read and will not operate as intended, although bottles without labels can be used if the user manually enters data.

A touch-screen interface gives access to all analyzer functions. The user interface has a home screen from which all user operations initiate. The home screen shows the current status of the analyzer and analysis results based on the current run mode selection. The software can show data in a number of user-selected formats, e.g., TOC, compensated and uncompensated conductivity, resistivity and temperature in engineering units with data logging and graphing of the data.

A user may connect a USB flash drive to the analyzer and download the contents of the data buffer, audit trail, alarm log and bottle analysis reports. Query the analyzer through an RS232 communications port to remotely interact with the analyzer and also download data records. Or communicate with the analyzer with Modbus® protocol via the Ethernet port. Print automatically or on demand with an RS232 port to a serial printer.

The analyzer permits compliance to 21 CFR Part 11 with password protection and an audit trail of user actions.

## Analyzer Startup Sequence

---

The analyzer goes through the sequence that follows when the power switch is set to on.

1. **Splash window:** The splash window shows at startup while the system launches the application.
2. **Verify lamp monitor:** After the system has initialized, it verifies that the lamp monitor works. The main lamp is set to on and the analyzer makes sure that a voltage is returned.
3. **Sample bottle check:** The system identifies if the bottles loaded in the bottle bay match the last known configuration. If the bottles contain RFID tags, the analyzer reads the tags and compares them against the information saved in the settings. If the RFID tag does not match what is saved in the settings, the settings are updated with the new information and a warning is triggered. If the settings list a non-RFID tagged bottle in one of the bottle positions and an RFID tag cannot be detected in that position, the analyzer assumes the bottle is still present.

4. **Start sampling:** If the analyzer is configured for online TOC, it starts to take a sample after power is supplied.
5. **Print header:** After the system has started up, it prints a daily header if a printer is attached.

## Run Modes

---

### The Analysis Cycle

An analysis cycle includes a flush of the analysis cell, oxidation and idle time. Idle time occurs only after an online TOC analysis is completed and only if the elapsed time (combined flush and oxidation time) is not more than the cycle time. The oxidation time changes based on the amount of total organic carbon in the sample. The flush time is configurable. The idle time changes based on the cycle time.

**NOTE** In the dual-stream toggle mode, the analyzer does an analysis cycle for stream 1 and then an analysis cycle for stream 2.

During idle time, the analyzer can operate in one of three ways: flow without conductivity, flow with conductivity or no flow. Refer to [Configure the General Settings](#).

To select the run mode, refer to [Select the Run Mode](#). Descriptions of the run modes follow.

### Online TOC Mode

In online TOC mode, the cell valve opens to flush the cell. When flushing is completed, the sample valve closes, the analysis starts, and initial conductivity and temperature readings are sent to the TOC algorithm. Conductivity is monitored until the oxidation is completed.

When oxidation is completed, the analyzer reports the results to the home screen, the data log and the printer, based on the printer settings and if the printer is connected. If the elapsed time is more than or equal to the cycle time in settings, the next online TOC analysis is started. If not, the analyzer goes to the idle mode.

### Conductivity Mode

In conductivity mode, the home screen shows the conductivity and temperature readings.

For dual-stream toggle mode, the analyzer analyzes source stream 1 for the amount of the print interval, or 30 minutes if a print interval is not enabled, and then toggles to other stream.

In conductivity mode, the analyzer first makes sure that the UV lamp is off and the cell valve is open to flush the cell. The analyzer reports the current readings for conductivity and temperature every time a new value is available. The reported value is an average of the data over the last two seconds. The average reading is also sent to the printer, based on the printout settings and to the data log. One data point is sent to the log every 60 seconds.

## Standby Mode

In standby mode, the analyzer makes sure that the lamp is off and the valves are open. To exit standby mode, select a different run mode.

## Offline Mode

In offline mode, the analyzer makes sure that the lamp is off, the valves are closed and flow through the analyzer has stopped. To exit offline mode, select a different run mode.

## Manual TOC Sample

A TOC analysis can be done manually. Push the **TOC manual sample** icon, then select the source stream for analysis if a dual-stream analyzer. The analyzer immediately stops its current operation and then does one TOC analysis. When the analysis is complete, the analyzer goes back to the mode selected on the run mode screen.

## Self-Clean Mode

Select the source stream for the self-clean operation if a dual-stream analyzer. If Timed is not selected, the self-cleaning continues until it is stopped by the user.

In manual self-clean mode, first the elapsed time is set to 0, the cell valve is opened to flush the cell and the lamp is set to on. If Timed is selected, the time that remains shows. If Timed is not selected, the elapsed time shows.

To stop the cleaning, push the red **X** or select a different run mode.

## Bottle Mode

---

### Calibration and Validation

Bottle mode is used to do calibration, validation and system suitability test procedures. Proper calibration of the analyzer is critical to optimum instrument performance. Such functions can be done automatically with the Onboard Automated Standards Introduction System (OASIS™) with the touchscreen interface. This method minimizes user intervention with the use of a prepackaged standards kit with RFID technology. Calibration, validation and system suitability test procedures can be done immediately or scheduled to be done later.

- Calibration assures the accuracy of instrument readings at regular intervals. This instrument is calibrated at the factory before shipment. It is not necessary to do a TOC calibration before the analyzer is put into service.
- Validation ensures the accuracy of the calibration. A standard solution of known value is analyzed to challenge the calibration.

- Calibration and validation involve the analyses of one or more standard solutions and blanks (protocols) to identify the analyzer response.
- In bottle mode, the analog output stays at the last online TOC, conductivity and temperature values. The TOC and conductivity alarms are deactivated.

Five functions are available under bottle mode: run standards, grab sample, excursion mode, bottle flush and unload bottles.

## Onboard Automated Standards Introduction System (OASIS)

The PAT700 Onboard Automated Standards Introduction System (OASIS) is used to do standards tests, grab sampling and excursion sampling. Through the bottle mode, various bottle test functions can be selected. The OASIS system is automated through the use of RFID technology. Refer to [RFID Technology](#). When standards bottles with RFID tags are installed in the system, the analyzer uses RFID technology to read and transmit data about the standards to the analyzer. This system removes the need for manual data entry.

Bottles without RFID tags may also be used. The standards data is entered manually when prompted by the analyzer.

## RFID Technology

The PAT700 analyzer Onboard Automated Standards Introduction System (OASIS™) uses Radio Frequency Identification (RFID) technology, a registered radio frequency device. The RFID system in the PAT700 analyzer operates over a very short distance to prevent any interference with other wireless communications.

The term RFID describes a system that transmits data wirelessly using radio waves. An RFID system includes a “tag” and a “reader/writer”. The tag is attached to the standards bottles used in calibrations (conductivity and TOC), validations, system suitability tests and excursion mode. The RFID tag includes a microchip attached to a radio antenna mounted on a substrate. The RFID tag is attached to the bottom of the standards bottle. The microchip contains data about the standard contained in the bottle. The PAT700 OASIS system contains four RFID reader/writers that are permanently mounted inside the analyzer. The RFID reader/writers align with the bottle RFID tags when the bottles are fully loaded in the analyzer.

The reader/writer retrieves the data stored on the RFID tags located on the bottom of the standards bottles. The RFID reader/writers have antennas that emit radio waves and receive signals back from the tags on the standards bottles. The information provided from the tag includes the identity of the standard, the concentration of the standard solution, date of expiration and other pertinent data.

The reader/writer takes the data received from the tag and passes the information in digital form to the PAT700 processor. The RFID system in the PAT700 can read and write to the RFID tags attached to the standards bottle. The writing feature lets the PAT700 write data to the bottles identifying that the bottle has been used and provides for writing of data for the exclusive excursion sampling feature.

The RFID system in the PAT700 does not require any user intervention to operate. The system operates automatically when bottle tests are done. The system automatically switches on and off to read and write data only when necessary. When enabled, the radio frequency modulation emitted from the antennas is fixed at 13.56 Mhz. There are no user-serviceable parts associated with the RFID system. The RFID reader/writer board assembly should only be serviced by a Beckman Coulter certified service representative.

Since the RFID labels on the standards bottles contain the data necessary for each standard, the labels must not be removed from the bottle. Without the label, the RFID reader/writer has no data to read and will not operate as intended. However, bottles without labels can be run if the user manually enters data.

## Data Log

---

The data log holds up to 5,000 records. The data log contains analysis results, alarms, bottle test results and audit trail entries. Since the audit trail is kept in the data log, each audit trail entry uses one of the 5,000 data log entries.

The data log operates in a first in first out approach. Once the data log contains 5,000 entries the oldest entry is replaced with the newest entry.

The contents of the data log shows in the Data Review screen. Refer to [Manage Measurement Data](#). The Data Review screen is populated only when data logging is selected in the security settings. The Data Review screen shows a list of all the data in the data log as will show on a printout.

The data shown on the Data Review screen is filtered based on the settings in the filter dialog box. Refer to [Set the Data Filter](#). Data is shown in chronological order from earliest to most recent. The list scrolls to display the earliest data.

## Default Settings

---

[Table A.1](#) shows the parameters and default settings of the analyzer.

**Table A.1** Parameters and Default Settings

Parameter	Default setting
<b>TOC Setup</b>	
Flush time	1 minute
Cycle time	0
Use pump	Disabled
Bypass flow during analysis	Disabled
Bypass Toggle Time	15 seconds
Average last results	Disabled
Flow during idle	With conductivity



**Table A.1** Parameters and Default Settings

Parameter	Default setting
Invert Digital Outputs	Disabled
Control with digital inputs	Disabled
Stabilization – time between analysis	2 hours
Stabilization – time	10 minutes
Stabilize cell prior to analyzing	Default
<b>System settings</b>	
Instrument name	PAT700SNXXXX (XXXX = serial number)
Location	
Language	English
Time format	24-hour
Temperature display	°C
Conductivity display	Uncompensated conductivity
Static TCP/IP address	192.168.0.105
Static gateway	192.168.0.1
Static Subnet Mask	255.255.255.0
Static gateway	
WINS server	Blank
DHCP	Enabled
<b>Alarm setup</b>	
TOC upper limit	500 ppb
TOC alarm	Disabled
Conductivity alarm	Disabled
<b>Analog outputs setup</b>	
TOC zero	0.0
TOC full scale	2000
Conductivity zero	0.0
Conductivity full scale	20.0
Temperature zero	0.0
Temperature full scale	100
On error, return	2.0
In Bottle Mode, output	3.0
<b>Printer setup</b>	
Printer model	DPU-414
TOC print	Continuous
Conductivity print	Disabled

**Table A.1** Parameters and Default Settings

Parameter	Default setting
Conductivity print interval	1 minute
Conductivity % change	1 %
<b>Security settings</b>	
Enable security	Disabled
Enable data logging	Enabled
Encrypt Exported Data	Disabled
Password expires in # days	60
Remember last # passwords	3
Automatically log off after # minutes	30
Administrator ID	Admin
Administrator password	123456
User's full name	Blank
User ID	Blank
User password	Blank
Change password	Enabled
<b>Bottles change settings</b>	
<b>TOC calibration:</b>	
Manually accept results	Enabled
Return to online mode	Disabled
Slope limit	15%
R2 limit	0.99
Display "as Received" reports	Disabled
<b>Conductivity calibration:</b>	
Manually accepts results	Enabled
Return to online mode	Disabled
Slope limit from previous	5%
Slope limit from factory calibration cal	10%
Use calibration resistor	Enabled
<b>TOC validation:</b>	
Return to online mode	Disabled
<b>System suitability:</b>	
Return to online mode	Disabled
<b>Grab Sample</b>	
Return to online mode	Disabled
Enable TOC Alarm	Disabled

**Table A.1** Parameters and Default Settings

Parameter	Default setting
Alarm on average	Default
<b>Bottle mode</b>	
TOC calibration setup	Use default settings
TOC calibration custom settings	All standards selected, 3 repetitions
Schedule bottle test	Current time
<b>Stream Select Settings</b>	
Stream Select Mode	Stream 1
Stream 1 Name	Stream 1
Stream 2 Name	Stream 2



# Replacement Parts and Accessories

 **WARNING**


**Personal injury hazard. Use of non-approved parts may cause personal injury, damage to the instrument or equipment malfunction. The replacement parts in this section are approved by the manufacturer.**

**NOTE** Product and Article numbers may vary for some selling regions. Contact the appropriate distributor or refer to the company website for contact information.

## Consumables

Description	Item no.
PAT700 Calibration Standards Kit, includes: calibration blank and 0.250, 0.500 and 0.750 mg C/L sucrose calibration standards in RFID bottles	FG7019202
PAT700 Validation Standards Kit, includes: calibration blank and 0.500 mg C/L sucrose calibration standard in RFID bottles	FG7019222
PAT700 System Suitability Standards Kit, includes: 0.500 mg C/L sucrose, reagent water and USP 1,4-benzoquinone solution in RFID bottles	FG7018402
PAT700 Conductivity Standards Kit, includes: NIST calibration traceable electrolyte solution in RFID bottle	FG7002602
PAT700 Validation Protocol Reagent Kit, liquid reagent for the installation and operation qualification protocol, includes: calibration standards kits (3x), validation standards kits (2x), system suitability standards kits (4x), conductivity standards kit and NIST traceable calibration resistor	FG7019232

## Replacement Parts

Description	Item no.
UV lamp, PAT700	FG7001014
Water filter, internal, PAT700	FG7001015

## Accessories

---

Description	Item no.
Conductivity meter calibration resistor, PAT700	FG7001009
PAT700 Septa Cap Kit, includes: 100 pre-cleaned caps for PAT700 grab sample bottles (60 mL)	FG7025011
PAT700 Excursion Bottle Assembly	FG7025000
PAT700, Excursion Sample Bottle Kit, includes: ten bottles with RFID tags (60 mL)	FG7025100
Portable carrying handle for PAT700	FG7001005
Printer, 120 VAC with cable for PAT700	FG7001016
Printer, 230 VAC with cable for PAT700	FG7001018
PAT700 TOC Blank Kit, includes: four 60 mL bottles	FG7018501
HDPE Bottle Kit, includes: twenty-five clean, 60 mL grab sample bottles with septa caps	FG0025031
IQ/QD protocol on CD, PAT700	FG7001010

## 铭牌 (Name Rating Plate)

产品名称	ANATEL PAT 700 总有机碳和电导率分析仪
规格型号	PAT700 DS
法定制造商名称	Beckman Coulter, Inc. 贝克曼库尔特（美国）股份有限公司
法定制造商 住所	美国加利福尼亚州，Brea市，S. Kraemer大街250号，邮编：92821
代理人名称	贝克曼库尔特国际贸易（上海）有限公司
代理人住所	中国（上海）自由贸易试验区德堡路379号4幢一层东A部位
生产工厂名称/生产地址	Hach Company 5600 Lindbergh Dr., Loveland, CO 80538
美国原产地	







# Related Documents

## **PAT700 DS, Instructions for Use**

PN DOC026.53.80298

- Specifications
- General Information
- Installation
- User Interface and Navigation
- Startup
- Basic Operation
- Advanced Operation
- Maintenance
- Troubleshooting
- Appendices

[www.beckman.com](http://www.beckman.com)

