

DOC023.52.00076.Jun05

EVITA[®] OXY

User Manual



LANGE 

© HACH LANGE GmbH, 2005. All rights reserved. Printed in Germany



Contents

Introduction	2	Programming USC 5000/6000/7000	20	Troubleshooting	40
Mechanical installation	4	Keypad and display layout	20	Error system	40
Transmitter	4	Factory settings	21	Troubleshooting guide -	
Assembly	6	Menu structure	22	OXY 4100/3150/4150 stand alone transmitter	42
OXY 4100	8	USC 7000 multidrop system.....	25	OXY 4100/3150/4150 transmitter	43
OXY 4150/3150	9	Setting of oxygen/temperature units and		USC	44
USC 5000/6000/7000	10	transmitter's current output.....	26	Technical Data	48
USC 6000/7000 19" version	11	USC 5000/6000 current output settings	27	Transmitter	48
Optional add-on module USC 6000/7000	12	USC 7000 current output settings	28	USC	50
Optional add-on module USC 6000/7000		USC 6000 relay output settings.....	29	HART®	52
19" version.....	13	USC 7000 relay output settings.....	30	Appendix I	53
Electrical installation	14	Calibration	31	Appendix IIa	54
OXY 4100/4150/3150 stand alone transmitter	14	Maintenance	33	Appendix IIb	55
USC 5000/6000 and OXY 4100/4150		Other Settings	34	Warranty, liability and complaints	56
point to point.....	16	System information.....	35	Contacts	57
USC 7000 and OXY 4100/4150 multidrop.....	17	Forced current and relay outputs	38		
Initial start up	18				
OXY 4100/4150/3150 stand alone transmitter	18				
System with USC 5000/6000/7000	19				

Introduction



OXY 1100 sensor



OXY 4100 transmitter



OXY 4150/3150 transmitter

EVITA® OXY sensors are used for measuring the concentration of dissolved oxygen in water – especially in controlling and monitoring aeration processes in wastewater treatment plants, but also in applications such as fish farms.

EVITA® OXY consists of an OXY 1100 sensor, an OXY 4100 transmitter and a USC Universal Signal Converter.

There are two versions of the transmitter – a ball float version, OXY 4100, and a probe version, OXY 4150/3150. The operating principle is identical for both versions.

There are three versions of the USC - a USC 5000 basic version, and a USC 6000 with added features, both point to point. A USC 7000 with HART® multidrop functionality enabling up to 15 transmitters on only two wires.

The EVITA® OXY 1100 sensor is the heart of the oxygen meter. The transmitter converts the measurements by the sensor into a current signal and at the same time also performs the necessary calculations/corrections. The signal converter is the display and programming unit and offers additional outputs.



Documentation needs to be consulted.



The user shall be made aware of that, if the equipment is used in a manner not specified by the manufacturer, the protection provided by the equipment may be impaired.



USC 5000 IP 67 (NEMA 4X)



USC 6000/7000 IP 67 (NEMA 4X)



USC 6000/7000 19"

The EVITA® OXY system offers several advantages:



2-wire transmitter

- simple and fast installation

Easy maintenance

- simple automatic calibration in atmospheric air initiated by using the TILTCAL® or the USC 5000/6000/7000
- self-cleaning ball float
- simple sensor replacement after 2-3 years

High reliability

- self-diagnosing
- membrane leakage detection
- fault indication on transmitter current output

Flexible communication

- HART® communication as standard gives added features
 - setting of measuring range and units from a distance
 - display of dissolved oxygen and temperature, remaining OXY 1100 sensor life and specific event codes
- Option module can be fitted in the USC 6000/7000 without the need for tools



Mechanical installation

Transmitter

Mounting on a handrail

The mounting bracket for OXY 4100 and 4150 can be mounted directly on a handrail using the supplied hose clips. Retighten the hose clips after a few days use to ensure a tight mounting of the mounting bracket.

In case of strong sideways forces, the PVC pipe should be mounted with supporting wires. This takes up some of the sideways mechanical forces on the pipe and avoids cracking of the mounting bracket.

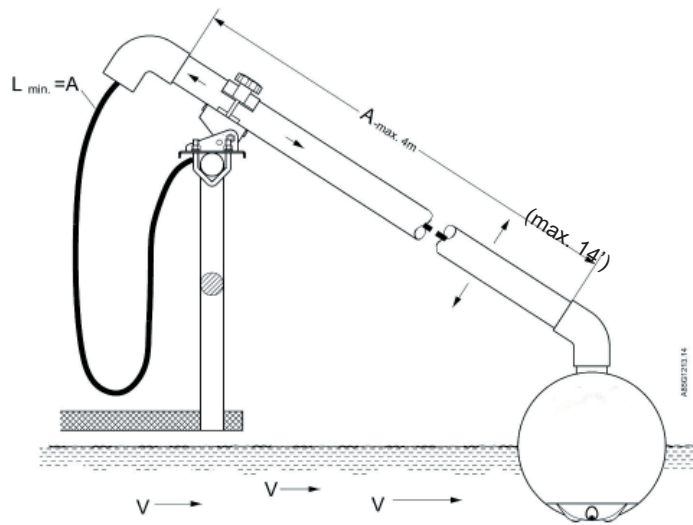
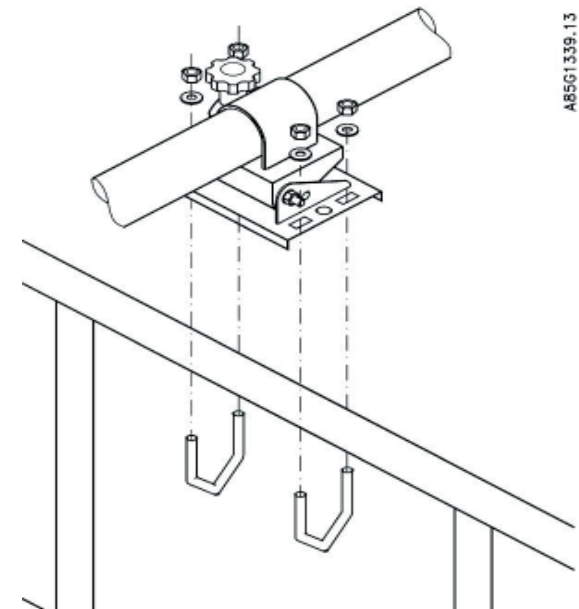

Fig. 1



AB5G1339.13

Fig. 2

Mounting on a concrete wall

The mounting bracket for OXY 4100 and 4150 can be mounted directly on to a concrete wall using 2 screws AISI 316 (diameter max. 10 mm or 3/8 UN).

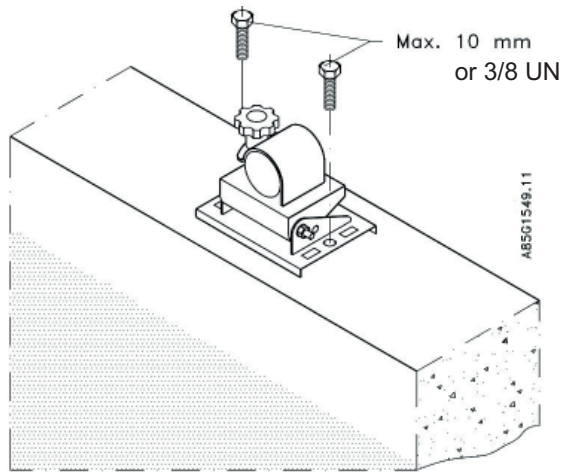

Fig. 3

Pipe mounting

The OXY 4150 transmitter can be mounted in a PVC pipe as shown in fig. 4.

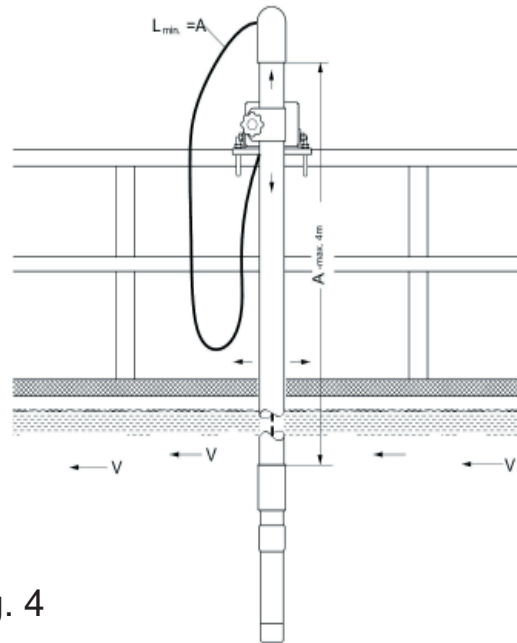

Fig. 4

Mounting of OXY 4150 transmitter using cable bracket

The strength of the transmitter cable is such that the transmitter can be allowed to hang from it.

Bracket (A) is available as accessory supplied by HACH LANGE. However, (B) is not.

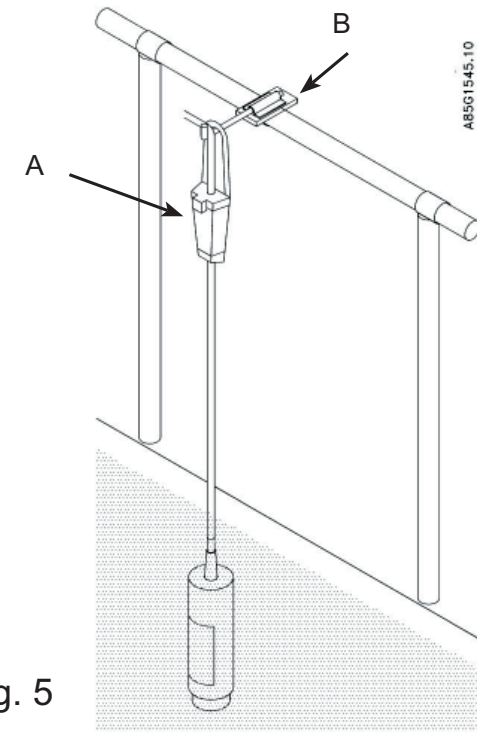
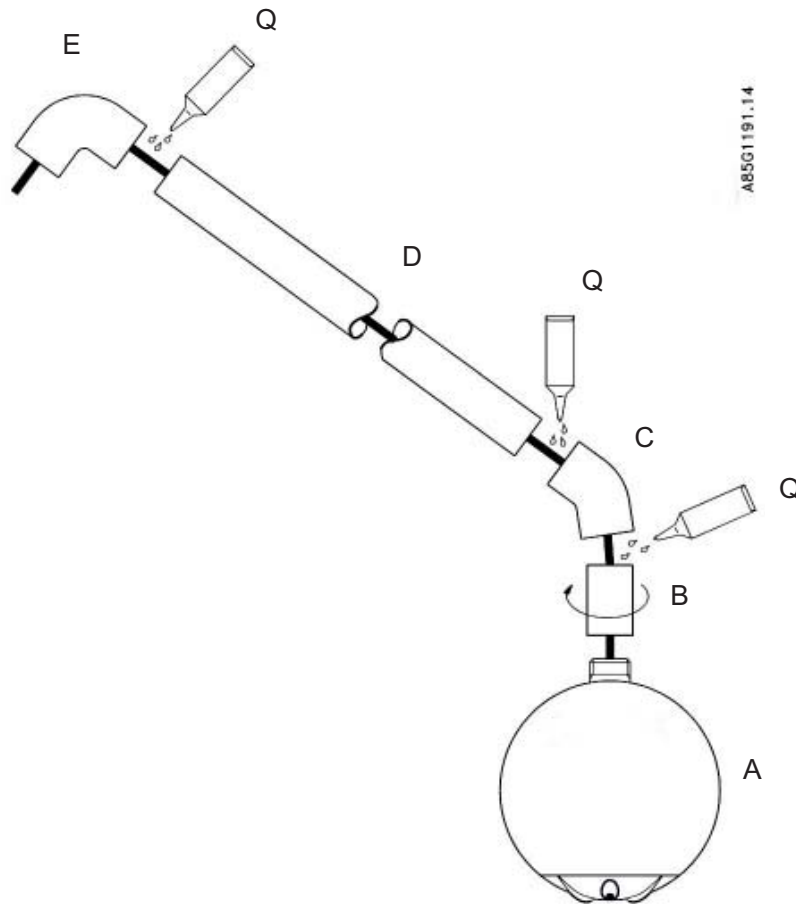

Fig. 5

Assembly

Ball float assembly

Mount the single parts as shown in fig. 6.



A: OXY 4100; 1 1/4" pipe thread

B: is supplied with transmitter

C: 45° PVC or ABS elbow; inside diameter: 50 mm or 1 1/2"; supplied by customer

D: PVC or ABS tube; 50 mm or 1 1/2"; supplied by customer

E: 90° PVC or ABS elbow; inside diameter: 50 mm or 1 1/2"; supplied by customer

Q: PVC or ABS adhesive; supplied by customer

Fig. 6

Probe assembly

Mount the single parts as shown in fig. 6a.

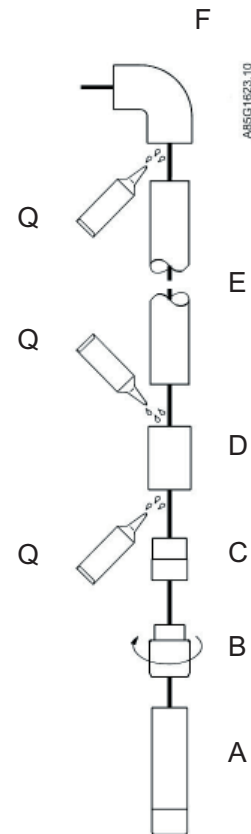

Fig. 6a

A: OXY 4150/3150; diameter 50 mm

B: adaptor with 1 $\frac{1}{4}$ " pipe thread (085G3325) or union with diameter 50 mm (081B0028); is supplied with system packages 1A and 2A

C: adaptor with 1 $\frac{1}{2}$ " and 50 mm outside diameter (081B0027); is supplied with system packages 1A and 2A

D: PVC or ABS socket; inside diameter: 50 mm or 1 $\frac{1}{2}$ "; supplied by customer

E: PVC or ABS tube; 50 mm or 1 $\frac{1}{2}$ "; supplied by customer

F: 90° PVC or ABS elbow; inside diameter: 50 mm or 1 $\frac{1}{2}$ "; supplied by customer

Q: PVC or ABS adhesive; supplied by customer

OXY 4100

Mounting and replacement of OXY 1100 sensor

Mount the sensor on the ball float as shown in fig. 7.
At mark 5: Turn until a "click" is heard.

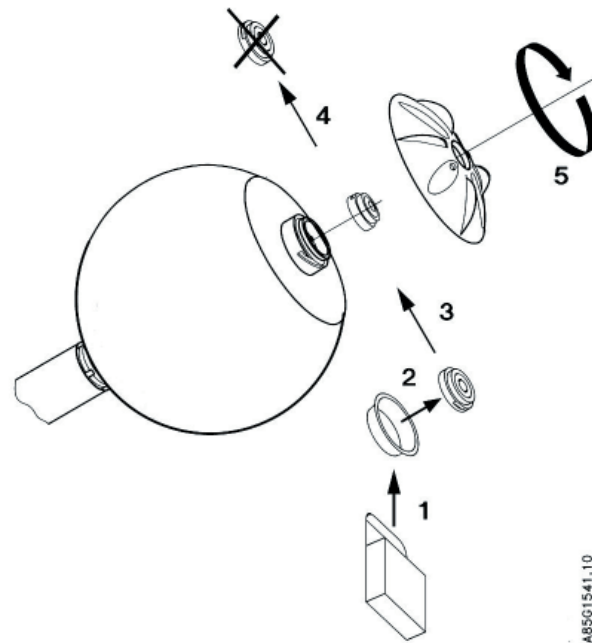

Fig. 7

OXY 4150/3150

Mounting and replacement of OXY 1100 sensor

Mount the sensor on the probe as shown in fig. 8.
At mark 5: Turn until a "click" is heard.

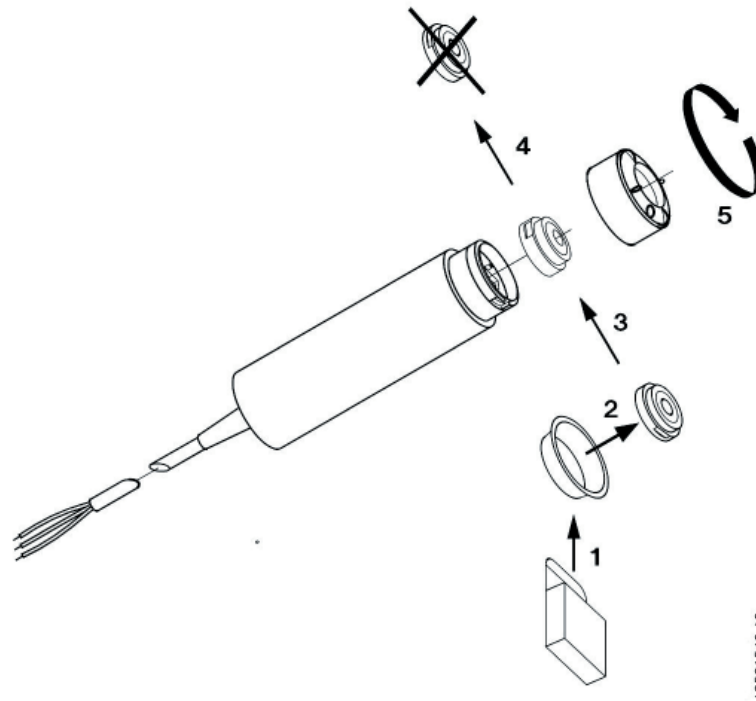

Fig. 8

USC 5000/6000/7000

Mounting on a handrail

Mount the bracket on a vertical or horizontal pipe using the two stainless steel hose clips.

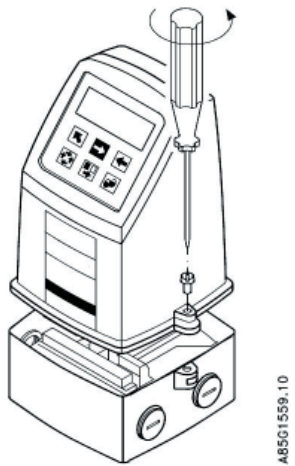

Fig. 9

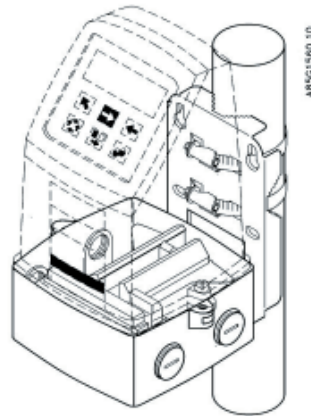

Fig. 10

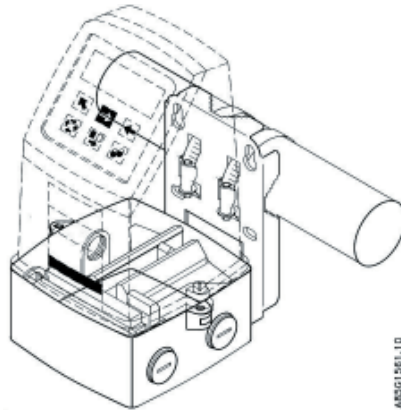

Fig. 11

Mounting on a concrete wall

Mount the bracket on to a wall using four screws (diameter max. 8 mm or 5/16 UN).

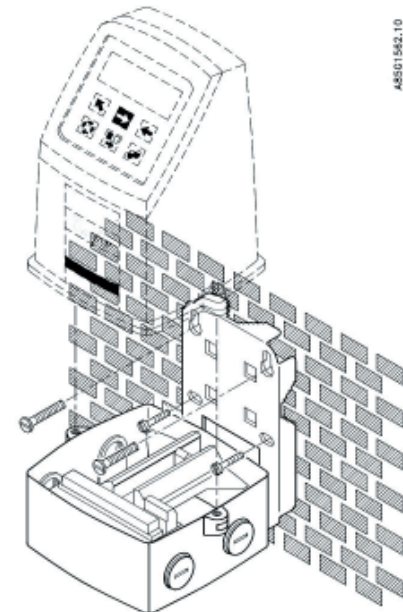

Fig. 12

USC 6000/7000 19" version

Mounting in panel

First mount the terminal board in the front panel IP 65 (NEMA 4X) enclosure, figs. 13 and 14, or the back of the panel bracket, fig. 15. Plug in the 19" USC 6000/7000 signal converter in the enclosure or bracket using the four small screws to tighten it.

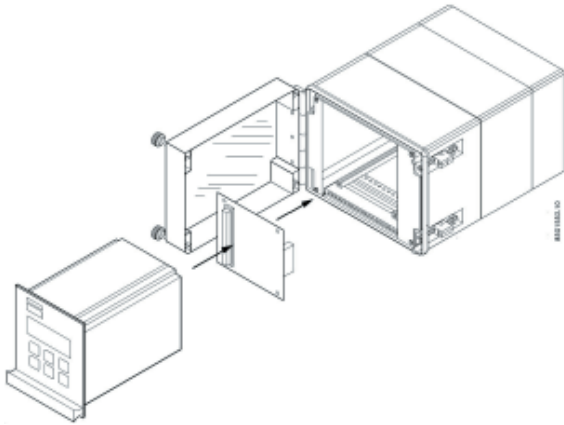

Fig. 13

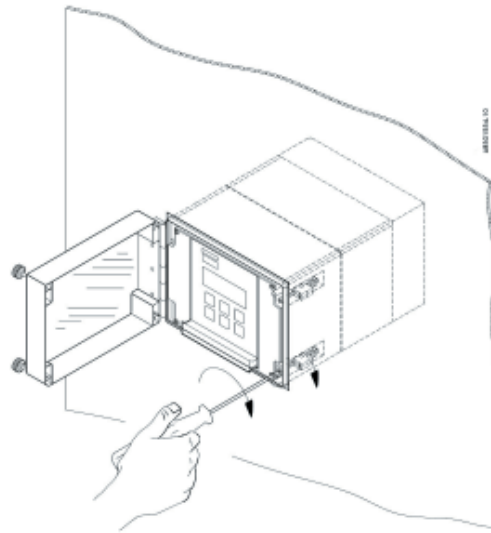

Fig. 14

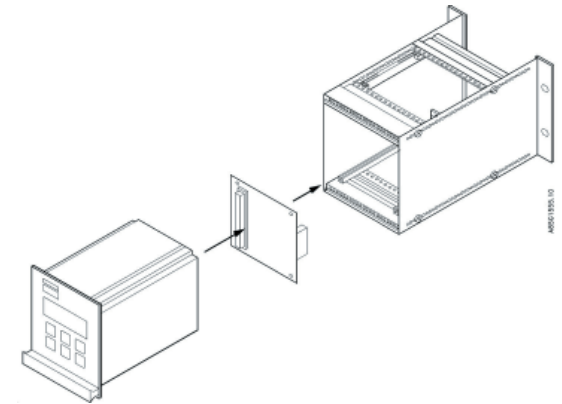

Fig. 15

Optional add-on module USC 6000/7000

Unpack the add-on module and locate it in the bottom of the signal converter as shown in fig. 16.

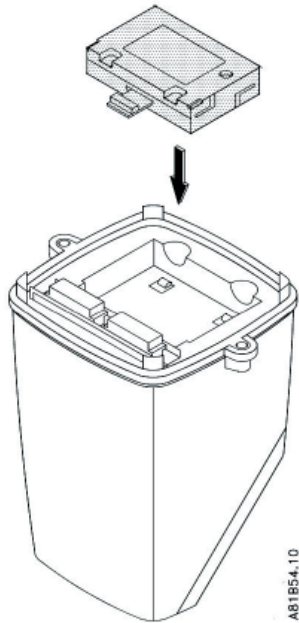

Fig. 16

Press the add-on module forward as far as possible. See fig. 17. Avoid touching the pc board and the sockets.

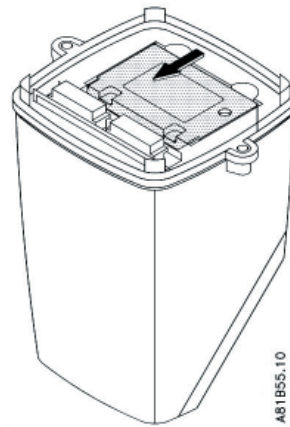

Fig. 17

The add-on module has now been installed and the signal converter is ready to be installed on the terminal box. The menus related to the optional add-on module will automatically become visible and electrical inputs and outputs are automatically established by power on.

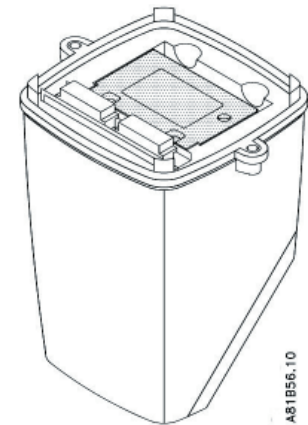

Fig. 18

Optional add-on module USC 6000/7000 19" version

Unpack the add-on module and locate it in the bottom of the signal converter as shown in fig. 19.

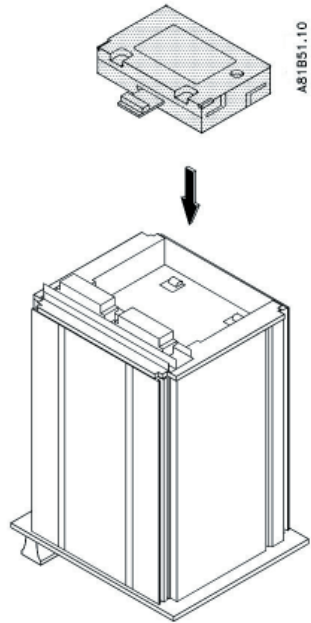

Fig. 19

Press the add-on module forward as far as possible. See fig. 20. Avoid touching the pc board and the sockets.

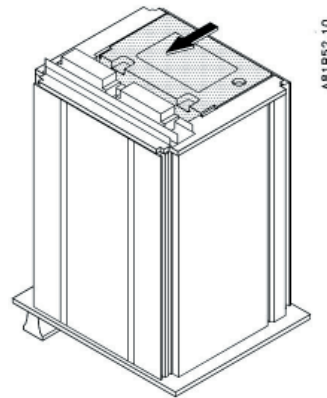

Fig. 20

The add-on module has now been installed and the signal converter is ready to be installed on the terminal box. The menus related to the optional add-on module will automatically become visible and electrical inputs and outputs are automatically established by power on.

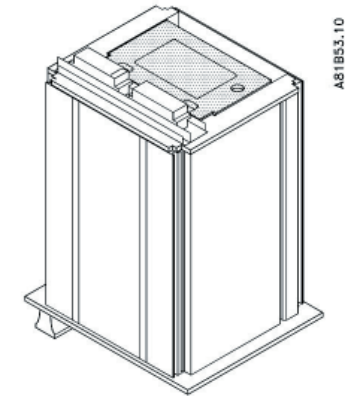

Fig. 21

Electrical installation

OXY 4100/4150/3150 stand alone transmitter

The transmitter is connected using the two-wire, shielded cable. The two leads carry supply voltage, a 4-20 mA current signal, and HART® communication.

If the cable is extended, the total length of the cable must not exceed 1000 m (3000'). Always use two-wire, shielded cable for the extension (min. 2 x 0.2 mm² (24 AWG)).

Examples of coupling to loop-powered display and PLC/SCADA system are shown in fig. 22, fig. 23 and fig. 24, respectively.

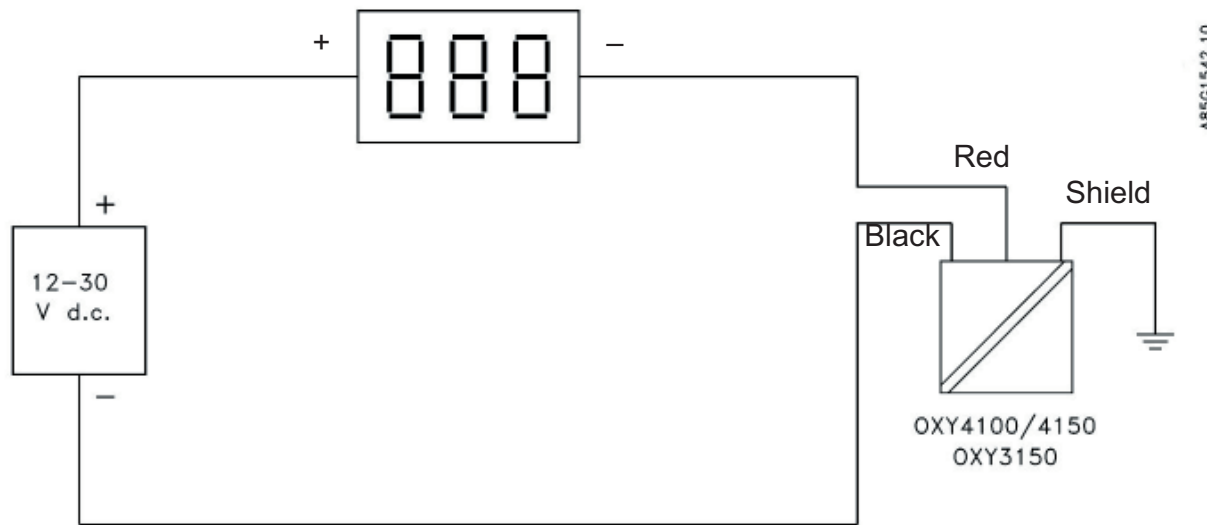

EVITA® OXY connected to loop-powered display.

Fig. 22



A suitable power supply shall be considered in the end-use application. The power supply must be a Class 2 power source (limited circuit) according to the National Electrical Code (NEC) and provided double/reinforced insulation between mains and the 12-30 V d.c. supply for the oxygen transmitter.

Note: Components like motors, pumps and computers may cause high voltage potential differences between the protective earth/ground wire and the water in the tank, that results in unstable readings. If this problem occurs, mount an earthing electrode in the tank to equalise the electrical potential of the water to PE.

If the flow velocity in the tank is high, it may cause a static potential locally. In this case, mount the earthing electrode close to the transmitter.

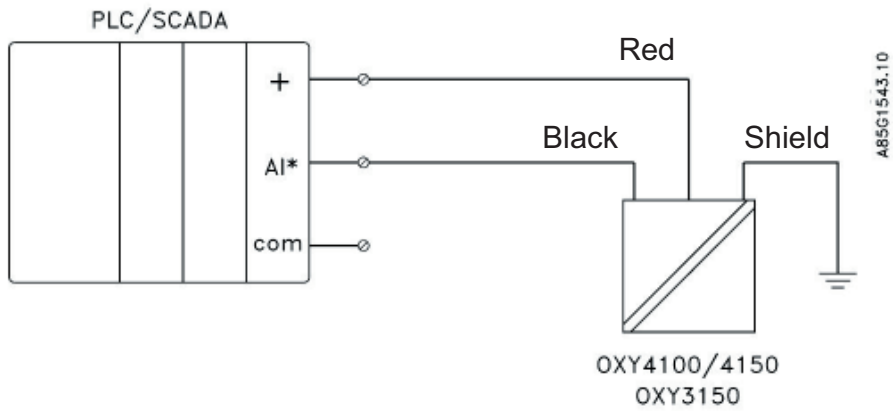

EVITA® OXY supplied from PLC/SCADA system.

Fig. 23

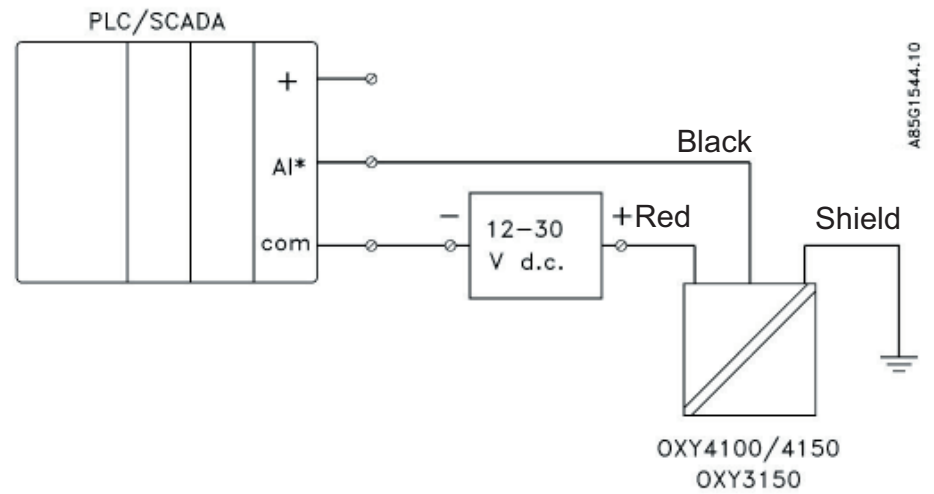

EVITA® OXY connected to a PLC/SCADA system with external power supply.

Fig. 24

USC 5000/6000 and OXY 4100/4150 point to point

The transmitter is connected using the two-wire, shielded cable. The two leads carry supply voltage, a 4-20 mA current signal and HART® communication.

If the cable is extended, the total length of the cable must not exceed 1000 m (3000'). Always use two-wire, shielded cable for the extension (min. 2 x 0.2 mm² (24 AWG)).

On the USC signal converter it is possible to disable the function of the digital input (used for calibration control on the EVITA INSITU 4100 transmitter).

Note: The digital input is available on both USC 5000, USC 6000 and USC 7000.

USC 5000/6000 - IP 67 version

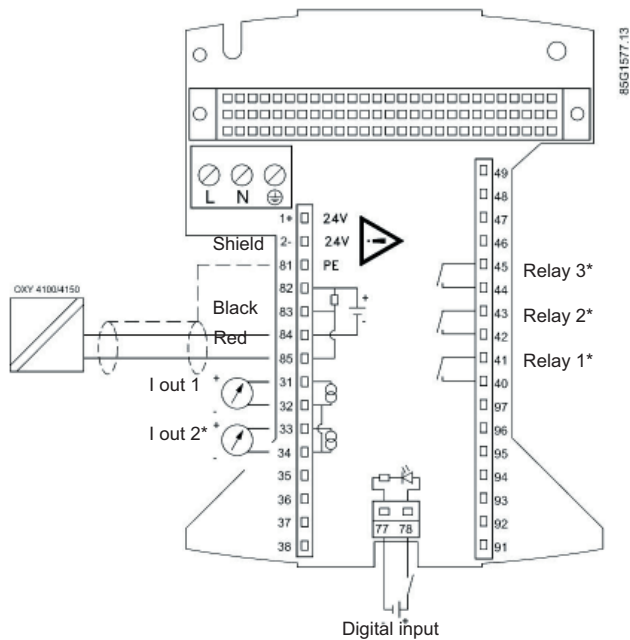

Fig. 25

*Only USC 6000

USC 6000 - 19" version

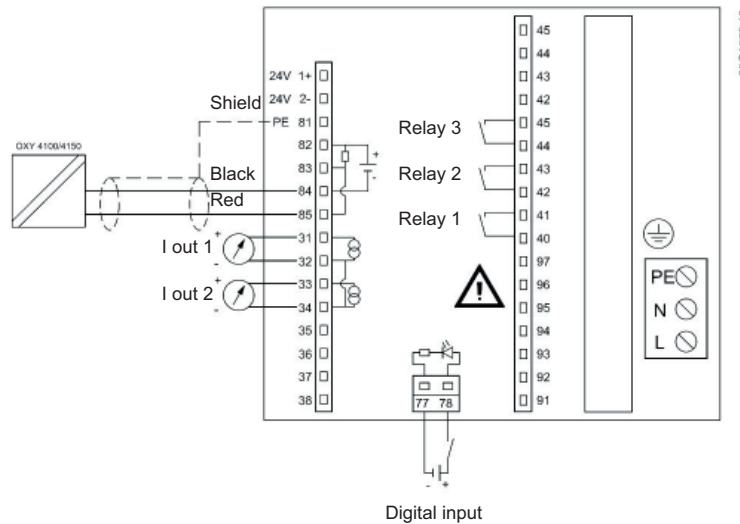
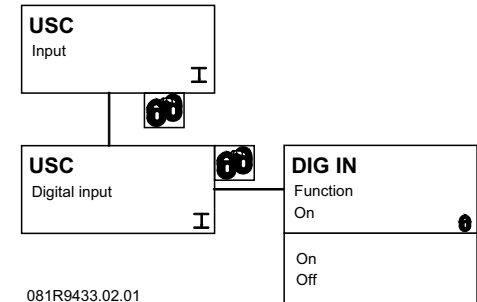

Fig. 25a

Fig. 26



081R9433.02.01

USC 7000 and OXY 4100/4150 multidrop

The USC 7000 is able to communicate with up to 15 EVITA® OXY transmitters using HART® multidrop protocol on only two wires.

Each transmitter should be connected in parallel outside the USC connection box and only two wires with shield mounted on the terminals in the USC 7000.

Note: Components like motors, pumps and computers may cause high voltage potential differences between the protective earth/ground wire and the water in the tank, that results in unstable readings. If this problem occurs, mount an earthing electrode in the tank to equalise the electrical potential of the water to PE. If the flow velocity in the tank is high, it may cause a static potential locally. In this case, mount the earthing electrode close to the transmitter.

Important: The below mentioned warnings concern both USC 5000, USC 6000 and USC 7000.

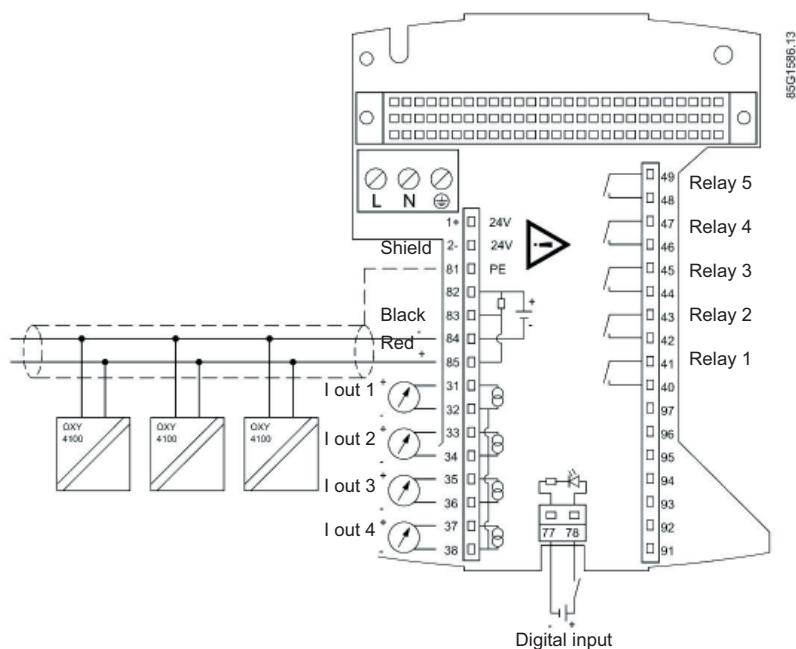

Fig. 27

- ⚠ The HART communication terminals (84/85) and the Digital Input terminals (77/78) of the Universal Signal Converter must not be connected to external voltage level above 30 V d.c.
- ⚠ The Relay terminals (40-49) of the Universal Signal Converter must not be connected to external voltage level exceeding 48 V d.c., 30 V rms or 42 V peak.
- ⚡ Protective conductor terminal. Required cable min. AWG16 or 1.5 mm² Cu.
- ⚠ Field wiring installation of the Universal Signal Converter must be in accordance with the National Electrical Code.
- ⚠ Mains supply 100 to 240 V a.c. from building installation (Overtoltage category II). A switch or circuit-breaker (max. 15 A) shall be included in the building installation. The switch/circuit-breaker shall comply with relevant requirements of IEC 947-1 and 947-3. It must be in close proximity to the equipment and within easy reach of the operator, and it shall be marked as the disconnecting device for the equipment.

Initial start up

OXY 4100/4150/3150 stand alone transmitter

1. Apply voltage with the OXY 1100 sensor pointing upwards in free air for 2 minutes. This will zero the sensor life counter. The life counter can be read via the signal converter (USC) or HART® communication.
2. Place the transmitter so that the OXY 1100 sensor points downwards, still in free air. Leave it in this position for 1 hour to allow the sensor to stabilise.
3. Calibrate in accordance with the instructions in the “Calibration” section p. 31.

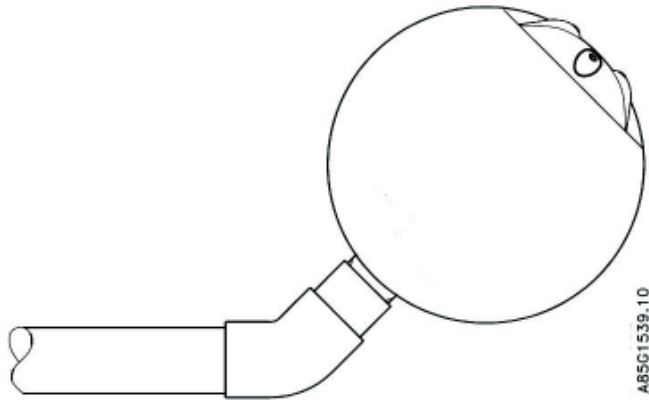

Fig. 28

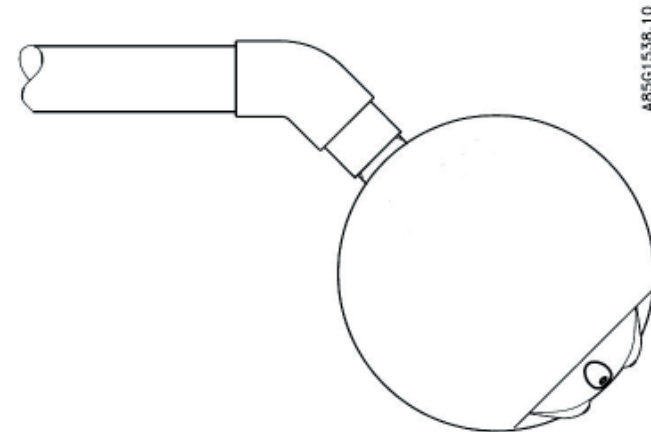

Fig. 29

System with USC 5000/6000/7000

1. Place the transmitter in free air so that the OXY 1100 sensor points downwards, see fig. 30.
2. Turn on the power to the signal converter USC 5000/6000/7000.
3. Leave the transmitter in this position for at least 1 hour to allow the sensor to stabilise before calibrating.
4. Check factory settings, see p. 21. Change if necessary.
5. Reset the lifetime counter, see fig. 32, p. 22.
6. Calibrate in accordance with the instructions in the "Calibration" section, p. 31.
7. After calibration is completed, place the transmitter in the measuring media.

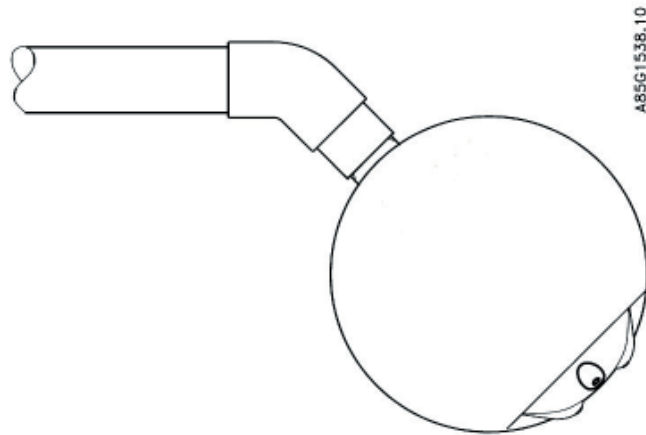

Fig. 30





Programming USC 5000/6000/7000

Keypad and display layout









Fig. 31



Various display symbols

-  Ready for change
-  Value locked
-  Access to submenu
-  Confirmation of choice



The keypad is used to set the EVITA® OXY and to step through the menus. The function of the keys are as follows:

TOP UP KEY (ESC)		This key (hold for 2 sec.) is used to switch between the operator menu and setup menu. A short press will cause a return to the overlying menu.
FORWARD KEY		This key is used to step forward through the menus in the setup menu.
BACKWARD KEY		This key is used to step backward through the menus.
CHANGE KEY		This key changes the settings or numerical values in the setup menu. In the operator menu it is used to step through the menus.
SELECT KEY		This key selects which digits to be changed.
LOCK/UNLOCK KEY (ENTER)		This key allows the operator to change settings and gives access to submenus.

IMPORTANT:

The USC starts up showing the menu “Language” in English. Press the  key until the wanted language appears in the display and press the  key. After the language is chosen, the USC will show “Concentration” in the operator menu (see p. 22).

The factory setting of the language can be reestablished as follows:

- Switch off the power supply
- Press the  key and switch on the power supply
- Release the  key after 10 seconds

The language is now reset to English.

Factory settings

The EVITA® OXY system is supplied with the following factory settings:

	Parameter	Factory settings	Options
USC 5000/6000/7000	Current output 1 (System packages 1 and 2)	0-20 mg/l	Range: min. 0 mg/l or ppm; 0% max. 50 mg/l or ppm; 500% Span: min. 1 mg/l or ppm; 10%
	Current output 2 (System package 1)	0-40 °C	Range: min. -10°C max. 70°C Span: min. 1°C
	Current outputs USC 5000/6000/7000	OFF	OFF ON
	Relays 1, 2 and 3 (USC 6000)	OFF	Alarm; Warning; Limit; Timer; OFF
	Relays 1, 2, 3, 4 and 5 (USC 7000)	OFF	Alarm; Warning; Limit; Timer; OFF
	TILTCAL®	Enabled	Enabled; Disabled
	Password	1000	1000-9999
OXY 4100/4150	Oxygen unit	mg/l	mg/l; ppm; %
	Temperature unit	°C	°C; °F
	Current output when not measuring	Low	High; Low; Hold
	Current output during error	Low	High; Low; Normal
	Time constant	40 sec.	10-300 sec.

If factory settings are satisfactory, proceed to p. 31.

Menu structure

The menu of the signal converter is built up in two parts. An **operator menu** and a **setup menu**.

Operator menu

The operator menu is for daily use. After the language has been selected, the signal converter starts up in the operator menu showing the actual concentration of dissolved oxygen.

The USC 5000/6000 is point-to-point installation while the USC 7000 is for a multidrop system. In fig. 32 menus marked with grey are only visible in the multidrop system. It is possible to hide some of the menus in the operator menu, see fig. 43, p. 34.

Fig. 32

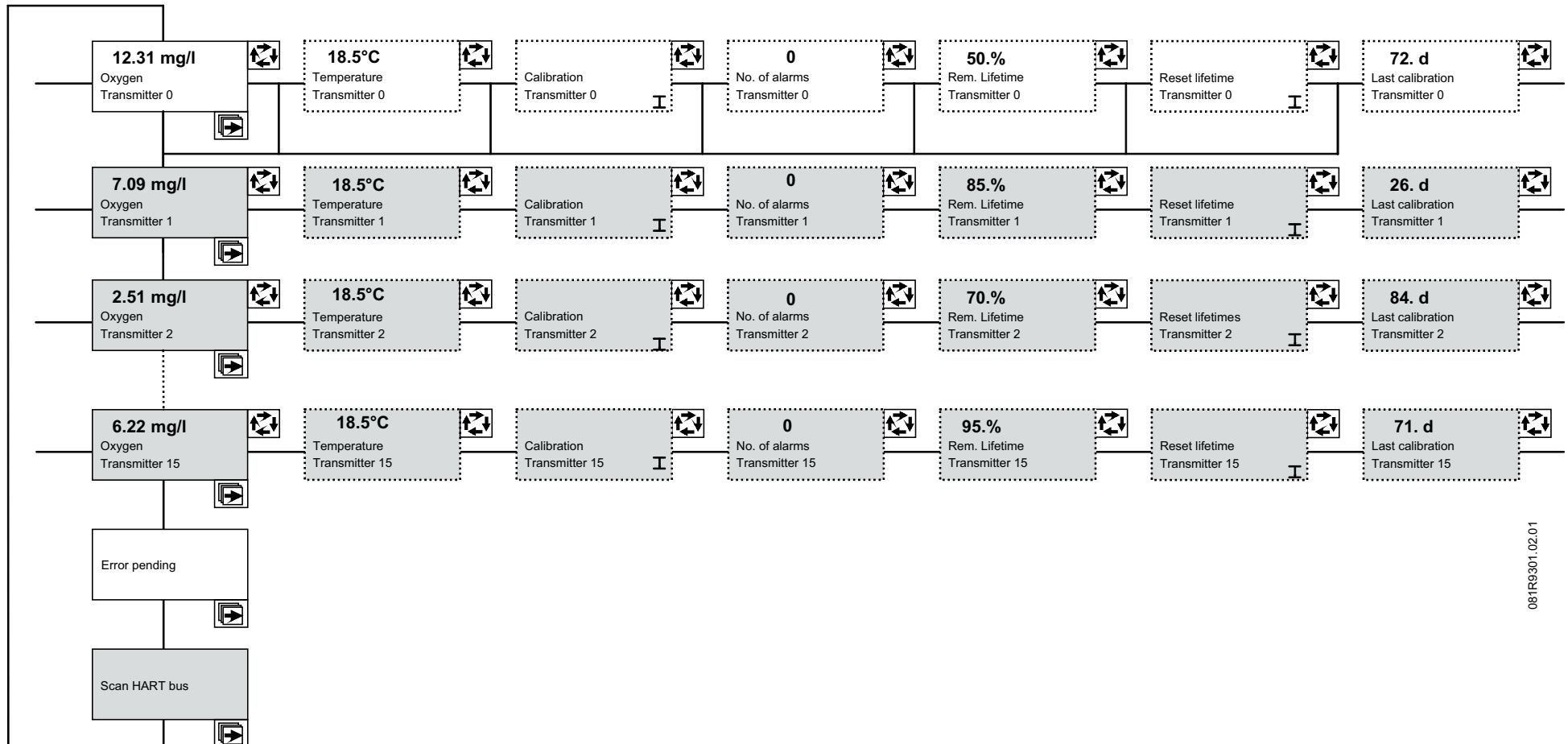



Setup menu

The setup menu is shown in an overview diagram (fig. 33) on page 24.

The setup menu consists of two parts:



- USC setup menu - for USC settings
- Transmitter setup menu - for transmitter settings

The setup menu is for commissioning and service and for changing the settings. Access to the setup menu is gained by pressing the  key for 2 seconds. The setup menu will operate in two modes:

• **View mode** is a read only mode. The preselected settings can only be scanned. The view mode is accessed by pressing the  key for 2 seconds. Instead of keying in the password, press the  key.

• **Setup mode** is a read and write mode. The preselected settings can be scanned and changed. The setup menu is accessed by pressing the  key for 2 seconds and entering the password. The factory set password is 1000, but can be changed to any value between 1000 and 9999.

The factory setting of the password can be re-established as follows:

- Switch off the power supply
- Press the  key and switch on the power supply
- Release the  key after 10 seconds

The password is now reset to 1000.

Fig. 33

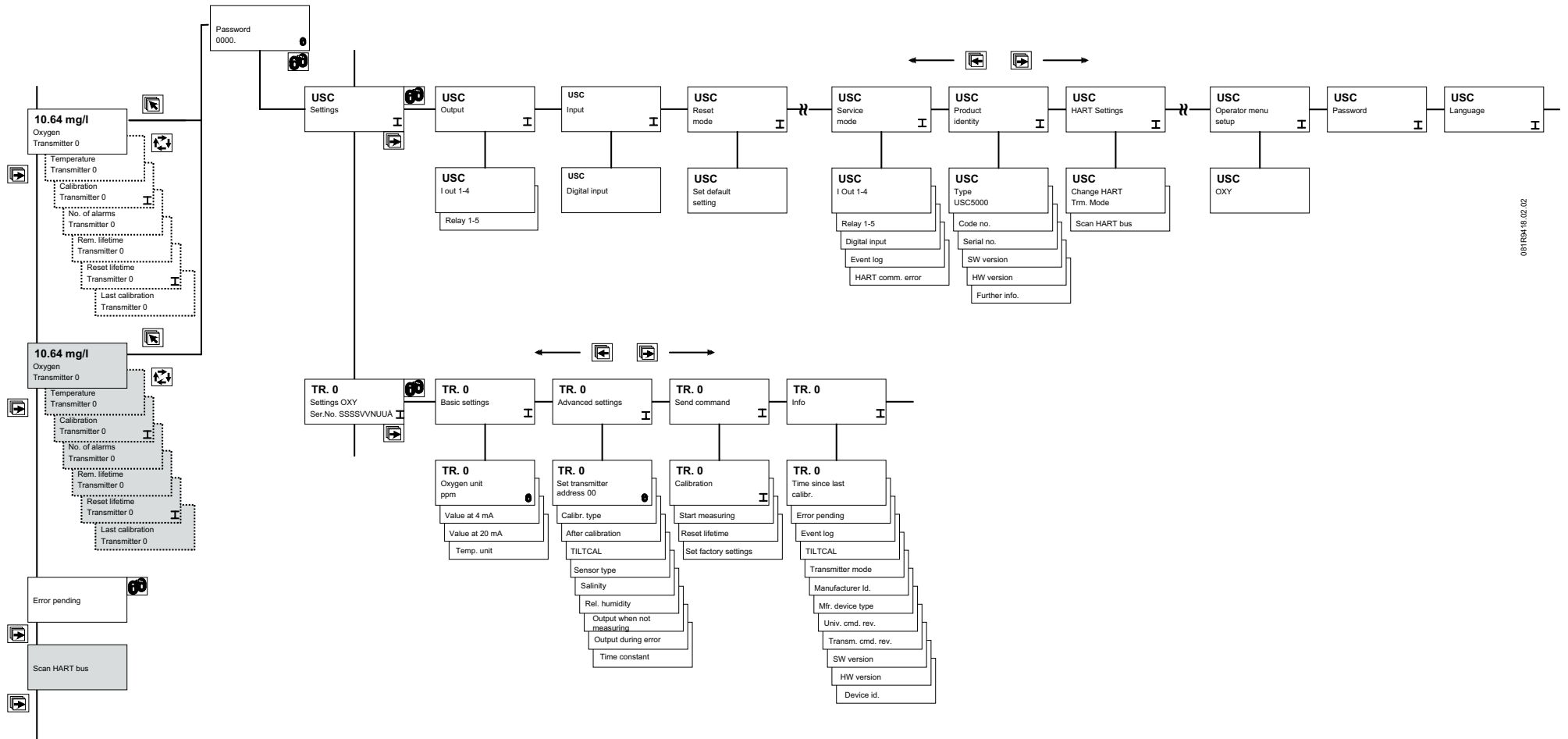

USC 7000 multidrop system

Changing transmitter address from default

To allow the USC 7000 to recognise the transmitter on the HART® bus, the transmitter needs a unique address between 1 and 15. The EVITA® OXY transmitter is factory delivered with the address 0, which is used for point-to-point installations (USC 5000/6000).

To programme the address of a new transmitter, connect the transmitter to the USC 7000 and press “Scan HART bus”. The transmitter will get the next available address between 1 and 15.

Note: If, before scanning the HART® bus, a transmitter with address higher than 0 was registered as interrupted, the new transmitter will be assigned this address.

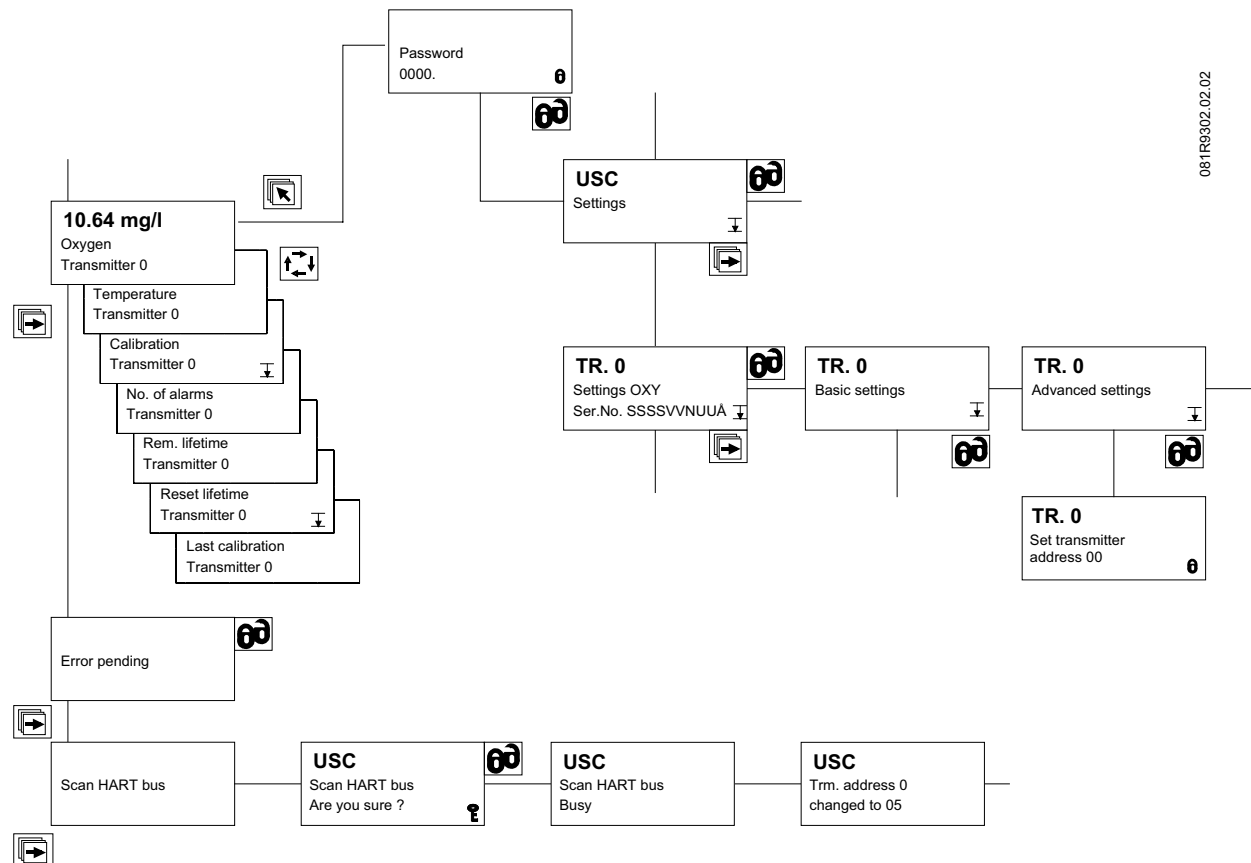

Fig. 34

Setting of oxygen/temperature units and transmitter's current output

If other settings are wanted, the factory settings can be changed as shown below.

Setting of the displays and current outputs units for oxygen and temperature can be done in "Basic settings". Setting of the transmitter's measuring range for oxygen can be done by changing the value at 4 mA and the value at 20 mA.

However the setting of current outputs range for oxygen and temperature is done as shown in fig. 36, p. 27 and fig. 37, p. 28.

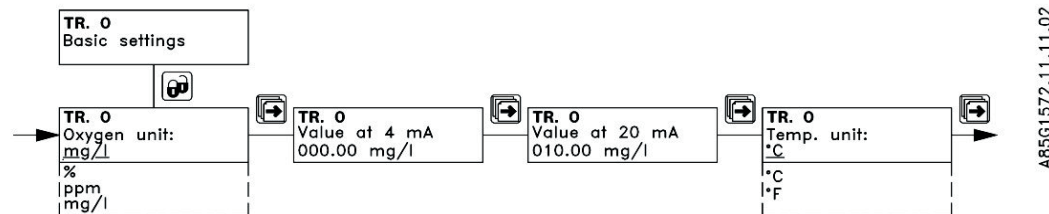
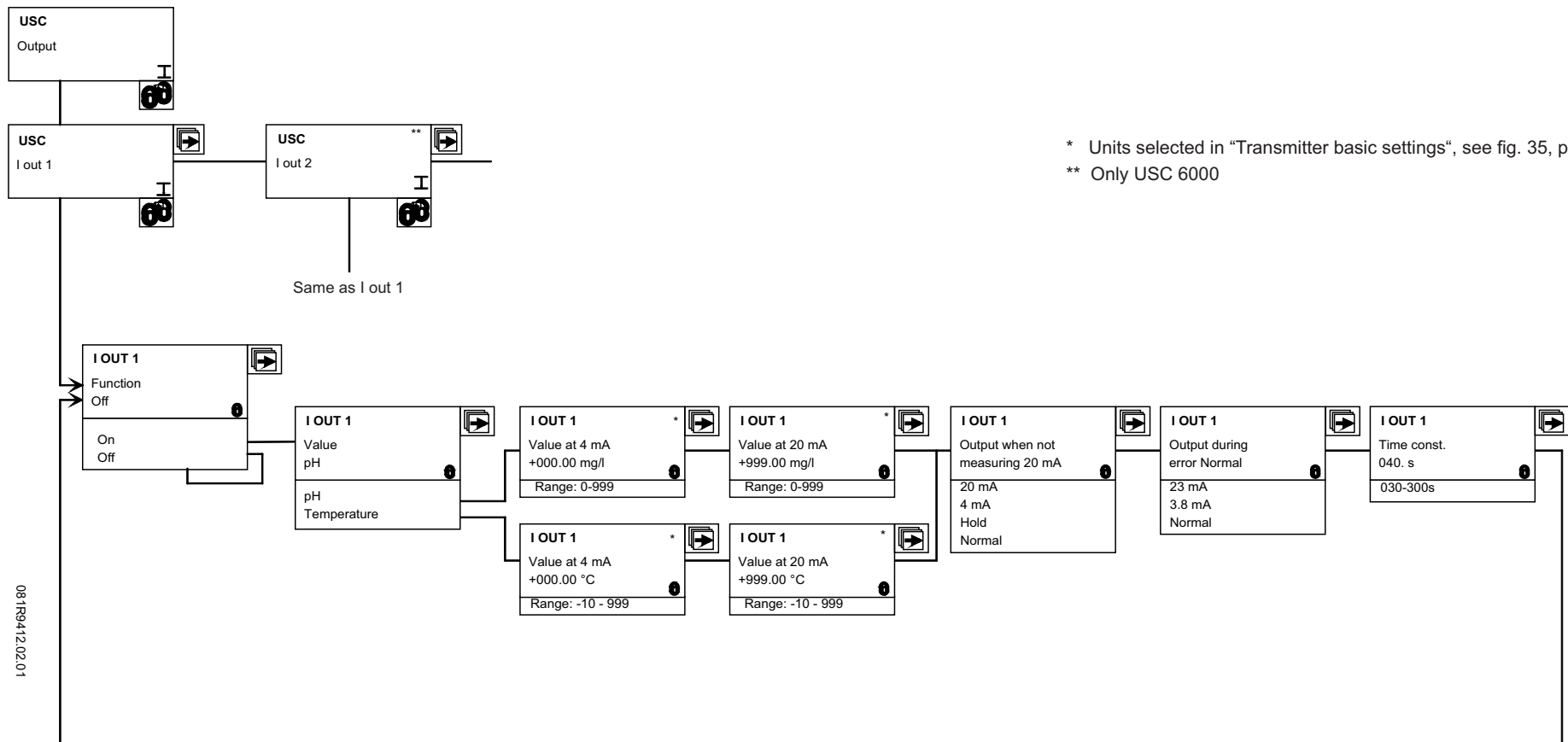

Fig. 35

USC 5000/6000 current output settings

Setting of current output 1 on USC 5000 and current outputs 1 and 2 on USC 6000.

Fig. 36



* Units selected in "Transmitter basic settings", see fig. 35, p. 26.
 ** Only USC 6000

081R9412.02.01

USC 7000 current output settings

Setting of current outputs 1 to 4 on USC 7000.

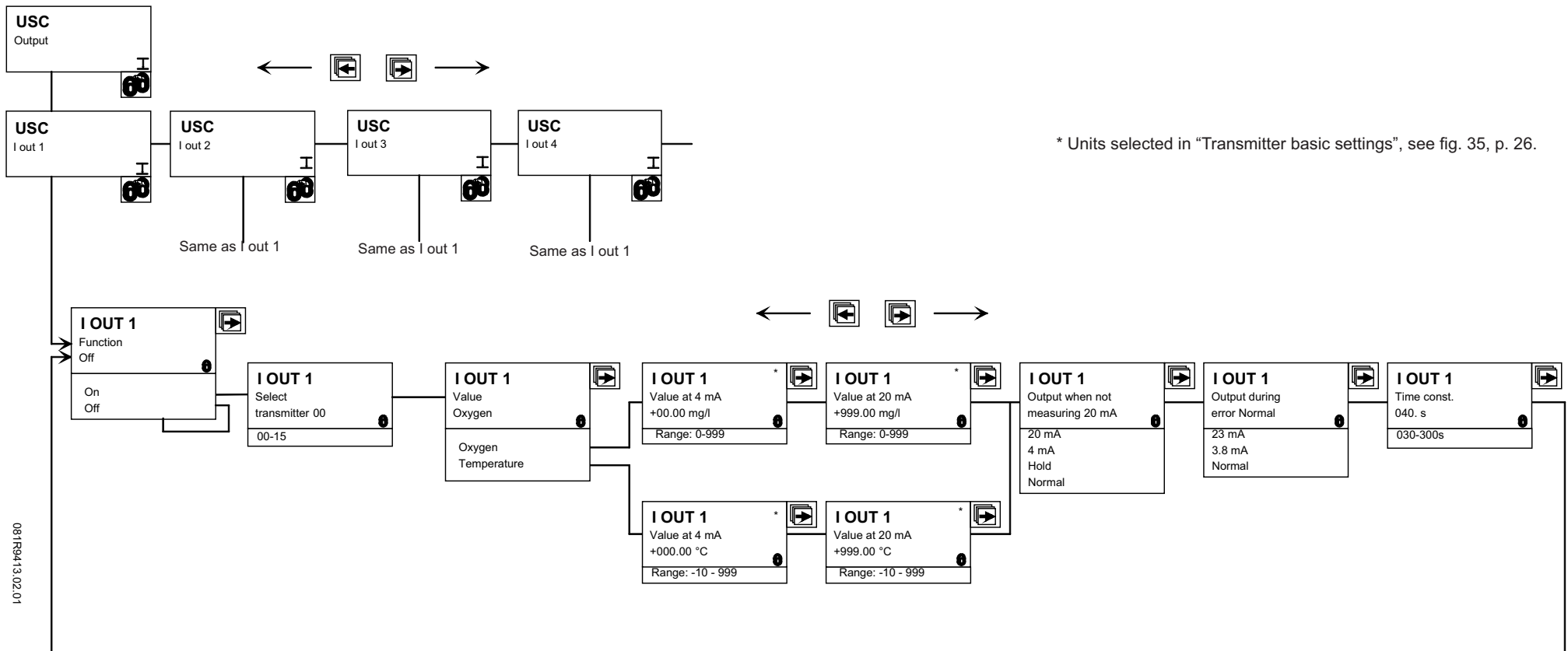

Fig. 37

081R0413.02.01

USC 6000 relay output settings

Setting of relay outputs 1 to 3 on USC 6000.

- * Units selected in "Transmitter basic settings" fig. 35, p. 26
- ** To allow the current output to stabilise after a cleaning, the USC locks the current output during "Cleaning time" and additional 10 minutes.

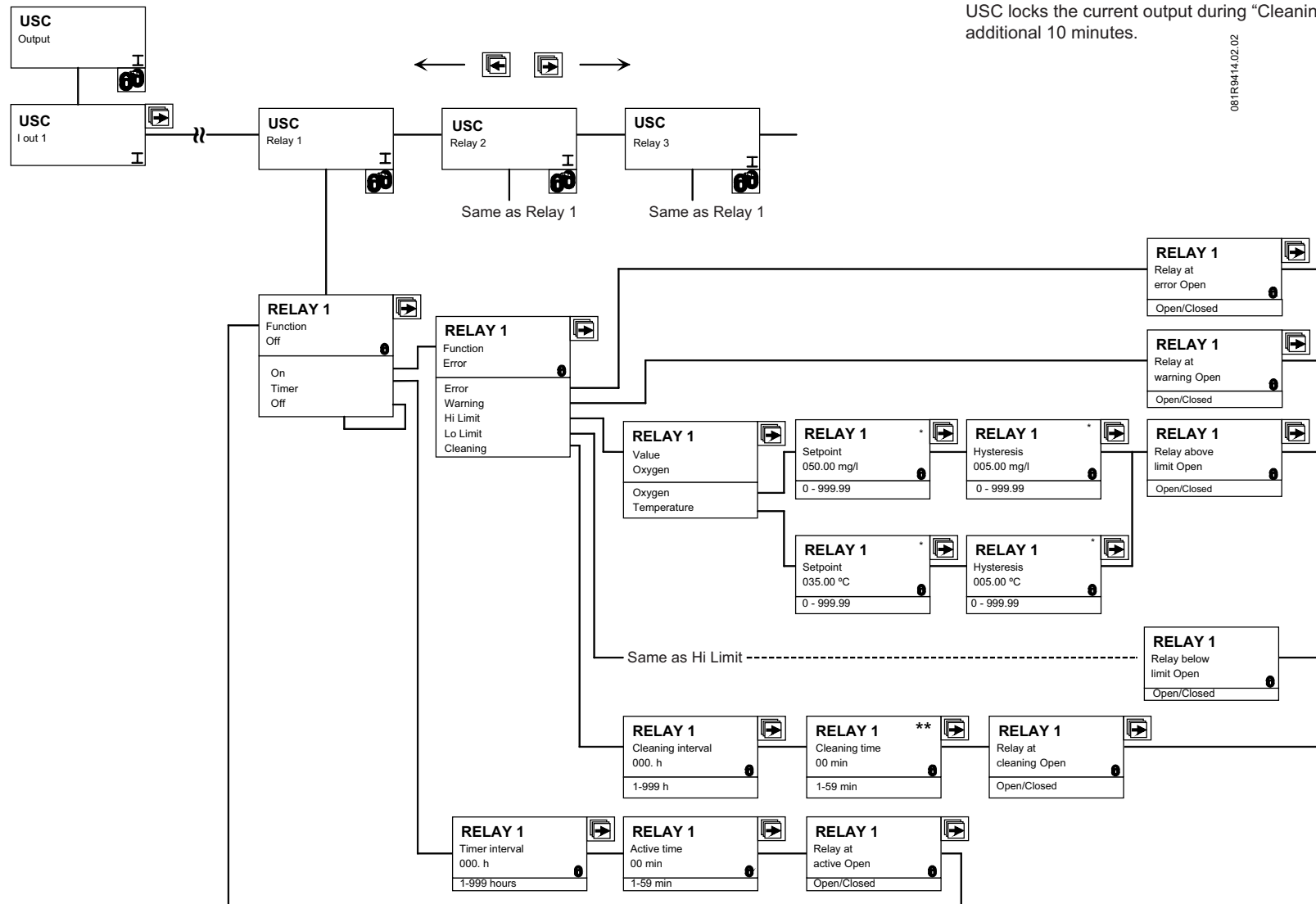

Fig. 38

USC 7000 relay output settings

Setting of relay outputs 1 to 5 on USC 7000

- * Units selected in "Transmitter basic setting", fig. 35, p. 26.
- ** To allow the current output to stabilise after a cleaning, the USC locks the current output during "Cleaning time" and additional 10 minutes.

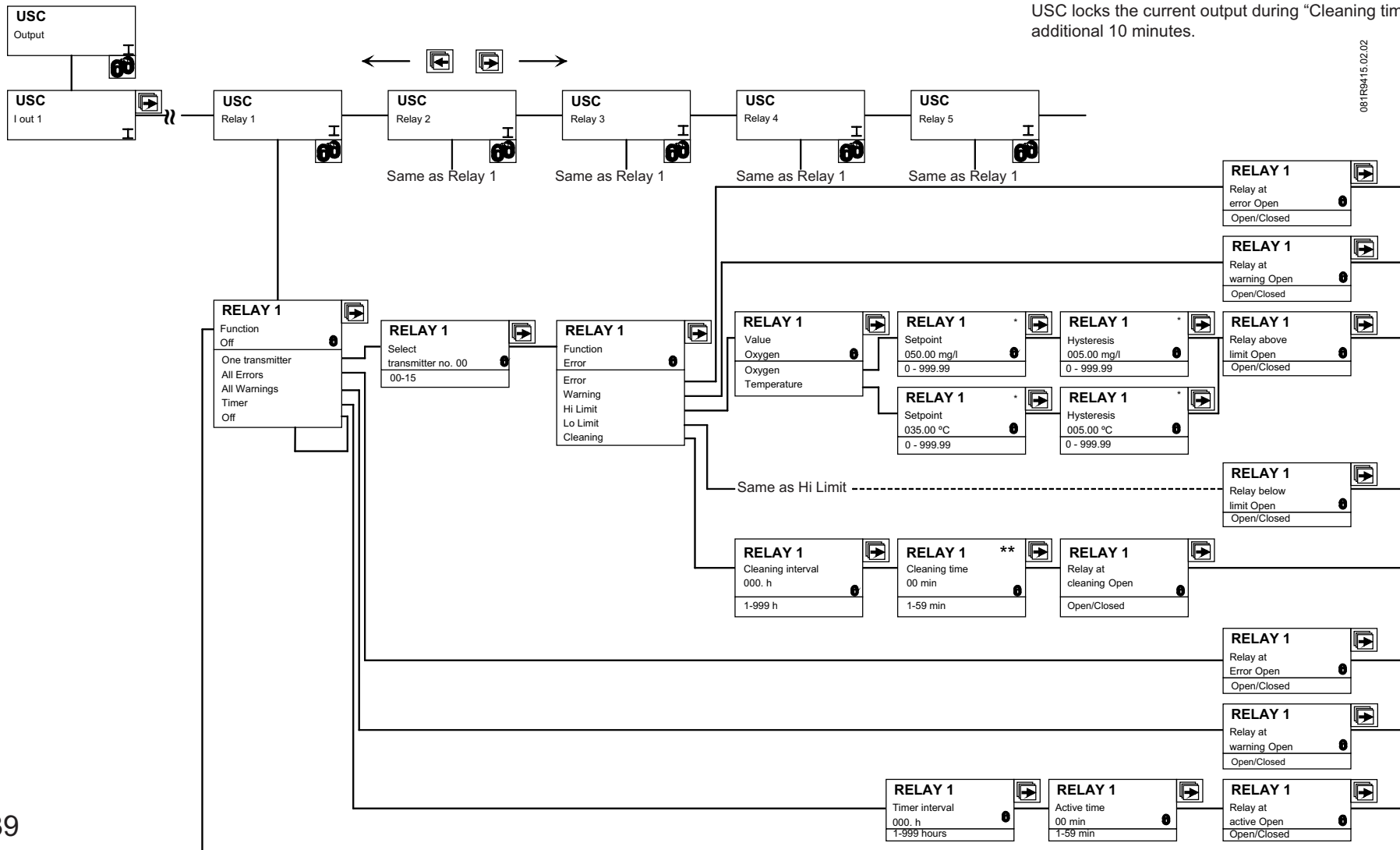

Fig. 39

Calibration

EVITA® OXY sensors must be calibrated in atmospheric air. Calibration every 6 months is recommended. Calibration can be initiated from the USC 5000/6000/7000 or by using the TILTCAL® feature in the OXY transmitter. During calibration, the OXY 1100 sensor must not be exposed to direct sunlight.

Before calibration, the OXY 1100 sensor must be cleaned, see section “Maintenance”. With fast calibration in atmospheric air a 1% system accuracy can be obtained. Temperature and barometric pressure compensation is made automatically during calibration via an internal temperature and pressure sensor.

Using TILTCAL®

Hold the transmitter with the OXY 1100 sensor upwards to initiate calibration by activating the tilt switch. After 5 min. turn the transmitter with the OXY 1100 sensor downwards and the transmitter has completed the calibration routine. During calibration, the current output signal is factory set to 4 mA. Optional 20 mA or the last measured value (Hold) can be chosen via the USC 5000/6000/7000.

TILTCAL®

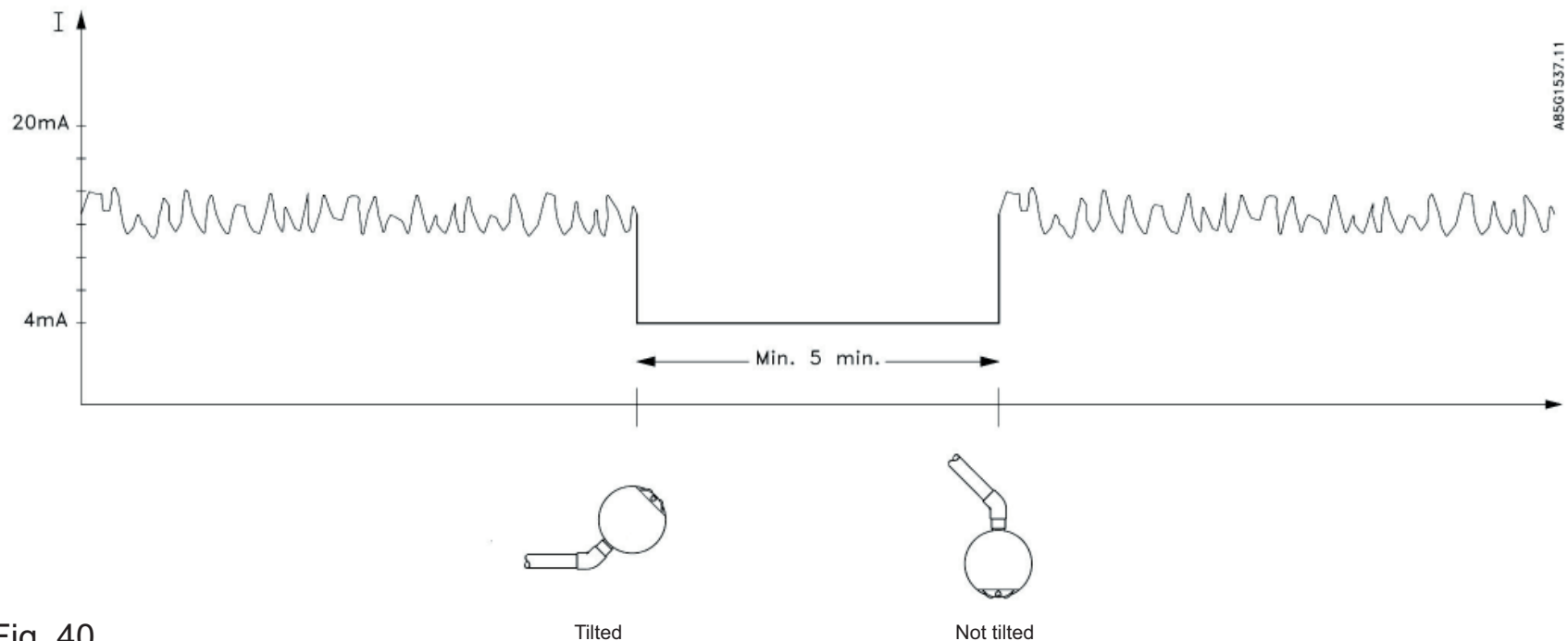



Fig. 40

If during the 5 minutes calibration period the transmitter is turned with the OXY 1100 sensor downwards, calibration stops and measurements continue with the previous calibration value. Temperature compensation is made automatically during calibration via an internal temperature sensor. In addition, using factory settings, compensation is also made for air pressure, relative humidity and salinity. These factory-set values can be changed via the USC signal converter or via HART® communication.

Using the USC 5000/6000/7000

In operator menu use the  key to select the "Calibration" menu and press the  key to initiate a calibration. Compensations for relative humidity and salinity can be made by entering these values using the USC 5000/6000/7000, see fig. 48, p. 37.

The set values and the significance of deviations from them are given in appendix I. A system accuracy of 0.5 % can be achieved by lifting the transmitter out of the medium and placing it with the OXY 1100 sensor downwards for 1 hour to make sure the sensor is completely stabilised. Calibration can then be initiated.

USC 5000/6000/7000 calibration

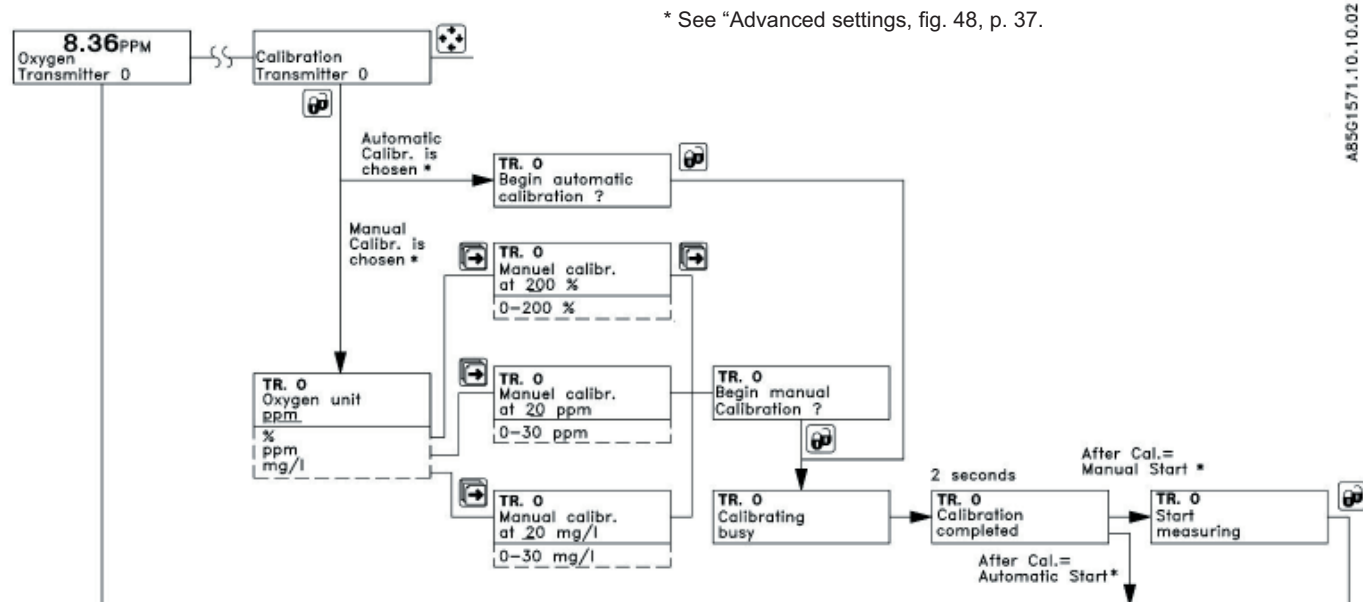

Fig. 41

Maintenance

Under normal conditions, the OXY 1100 sensor will operate for 2-3 years and can be replaced in a few minutes.

General maintenance of the EVITA® OXY sensor is limited to cleaning about every 2-3 months and calibration about every 6 months.

Cleaning (OXY transmitter)

During cleaning, the sensor must not be allowed to remain pointing upwards for more than 3 minutes at a time if the TILTCAL® function is enabled, otherwise a calibration cycle will start. The TILTCAL® function can be disabled according to fig. 48, p. 37.

1. Lift the transmitter out of the medium.
2. Clean the sensor with pure water, to which a little cleaning agent/washing-up liquid can be added.
3. Dry the sensor with a soft cloth.
4. Immerse the transmitter into the medium to be measured.

Cleaning (USC signal converter)

When considered necessary, clean the USC signal converter using a soft moist cloth.

Replacement of sensor

1. Remove the defective/worn sensor.
2. Insert new sensor (see fig. 7, p.8 or fig. 8, p. 9).
3. Reset the lifetime counter (see p. 18 or fig. 32, p. 22).
4. Place the transmitter so that the OXY 1100 sensor points downwards. Keep it in this position for at least 1 hour to allow the new sensor to stabilise (see fig. 29, p. 18).
5. Perform calibration (see section "Calibration" p. 31-32).

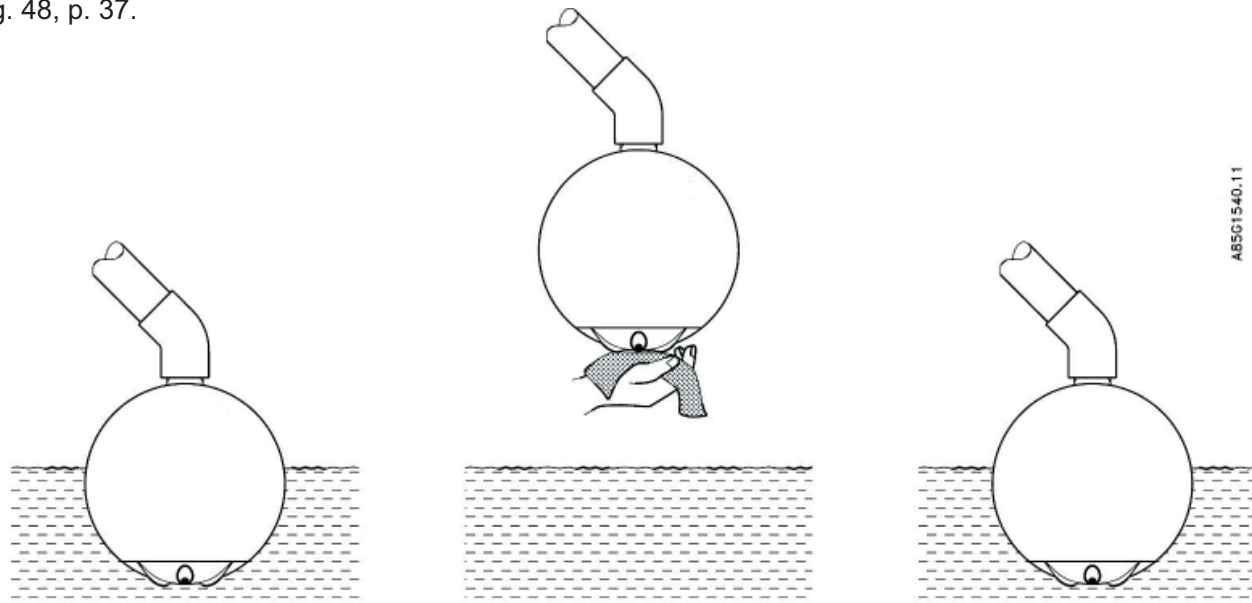
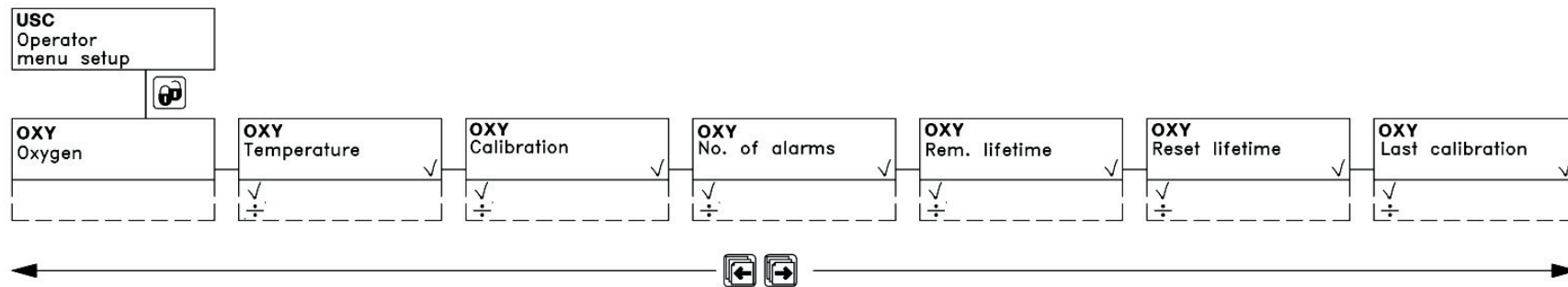

Fig. 42

AB501540.11

Other Settings

In the “Operator menu setup” it is possible to hide all menus except “Oxygen” in the operator menu.



A85G1569.10.10.02

- A ✓ in the operator menu setup means that this reading is shown in the operator menu.
- A ⊘ in the operator menu setup means that this reading is not available when viewing the operator menu.

Fig. 43

System information

Transmitter information

In the menu "Info" it is possible to view various information about the transmitter, e.g. time since last calibration, transmitter mode and software and hardware versions.

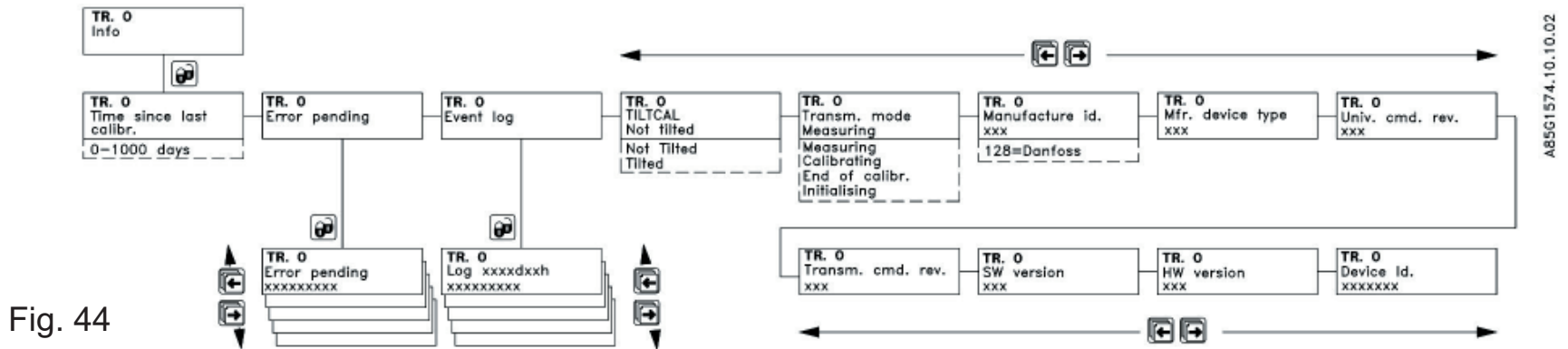

Fig. 44

USC information

In the menu "Product identity" it is possible to read the USC type (5000/6000/7000) and the serial number.

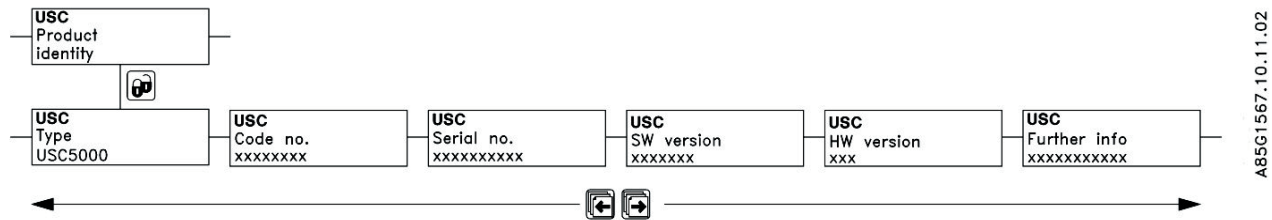

Fig. 45

Reset mode

The factory settings can be re-established as shown in fig. 46.

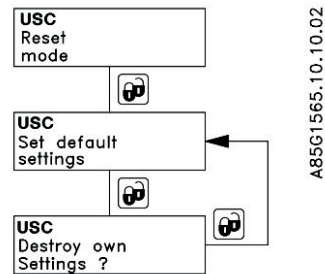

Fig. 46

Send command

In the “Send command” menu it is possible to start calibration, to start measuring after calibration, to reset lifetime and to set factory settings.

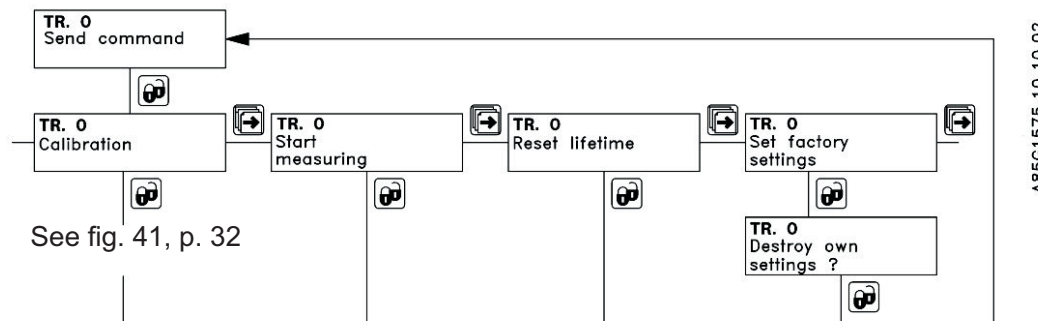

Fig. 47

Advanced settings

In the “Advanced settings” menu it is possible to choose which calibration type to be used and which type of start after calibration. Furthermore factors for compensation for salinity and relative humidity can be keyed in.

“Automatic calibration” means calibration in atmospheric air and “Manual calibration” means calibration in a standard solution where the concentration of oxygen is keyed in, see fig. 41, p. 32.

“Transmitter address” has to be 0 for current output to function in a point-to-point installation using USC 5000 or 6000. When operating in multidrop system using USC 7000, the transmitter must have a unique address between 1 and 15.

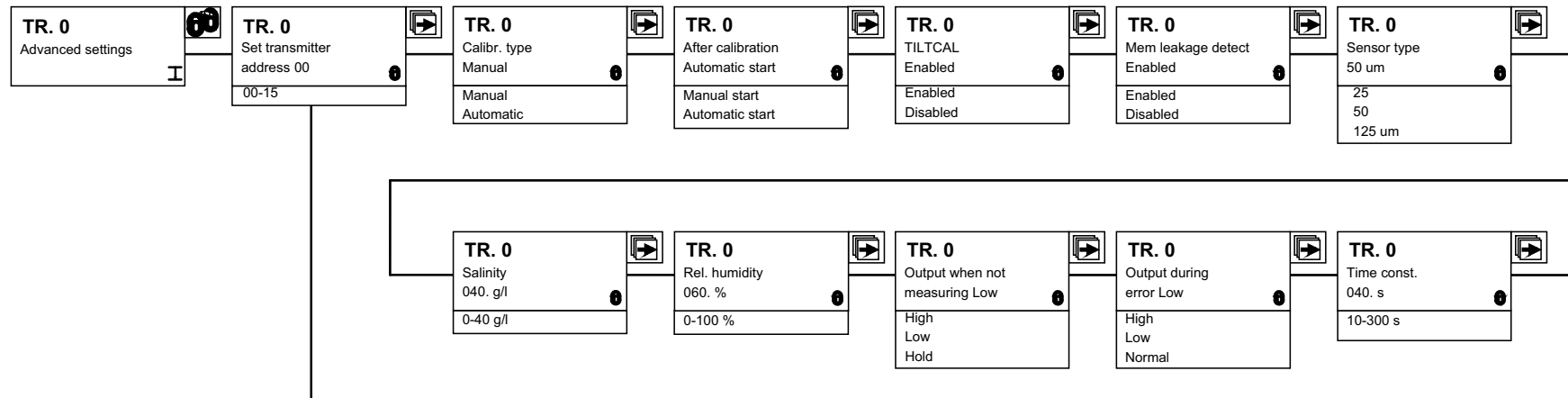

Fig. 48

Forced current and relay outputs

Service mode

In the “service mode” it is possible to control the relay and the current outputs directly. This may be useful when e.g. a control loop is to be adjusted or if an alarm signal should be checked.

The quality of the HART® communication is displayed in the “HART comm. error” submenu. The quality is shown as:

VVV XXXX YYY % ZZ

where

- VVV is the number of received messages without any errors,
- XXXX is the number of received messages with errors,
- YYY % is the percentage of messages that had errors
- ZZ is the number of messages that were eliminated, i.e. max. number of retries was reached.

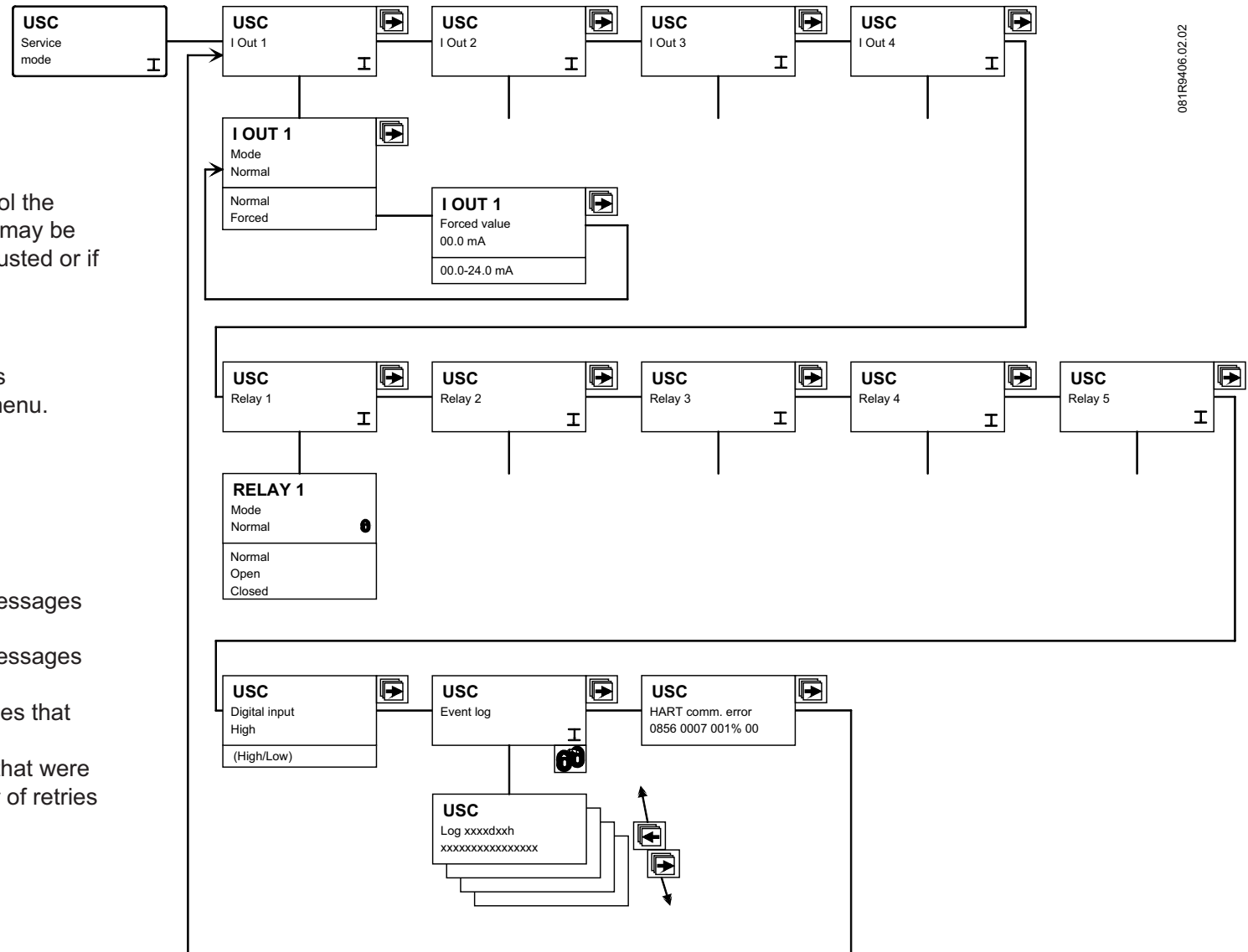



081R9406.02.02

Fig. 49

Troubleshooting

Error system

The EVITA® OXY has an advanced self-diagnostic system. If there is an error or a warning, a flashing bell  is displayed. To view the pending error information, press the  key in the operator menu – see below.

The USC and the transmitter each has an 'event log' that stores past errors, information and warnings.

To access the USC event log, see fig. 49, p. 38. To see the transmitter event log, see fig. 44, p. 35.

Operator menu

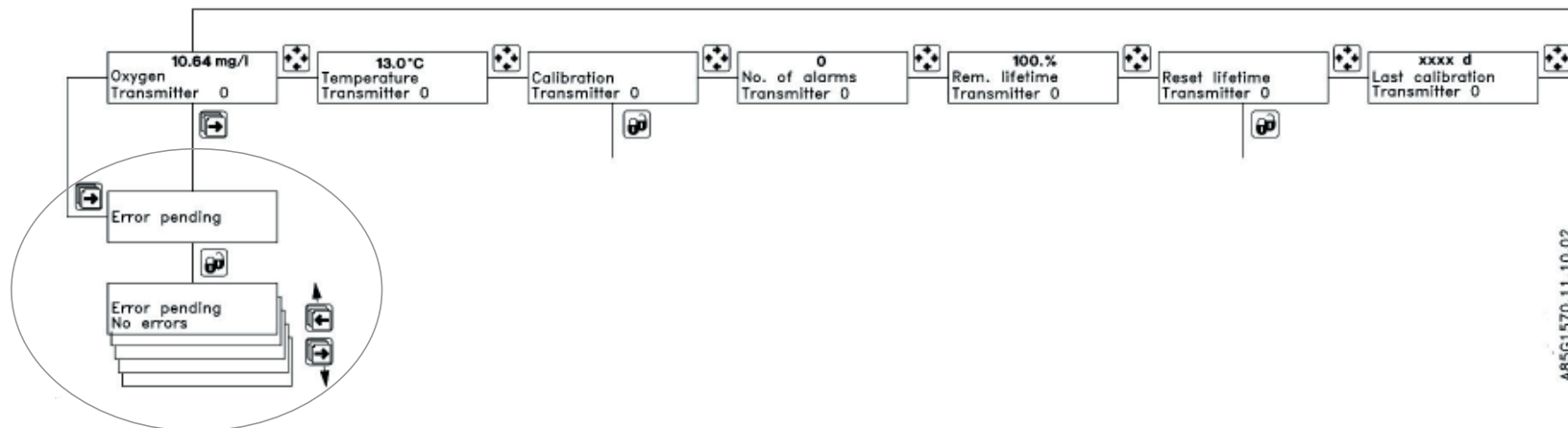
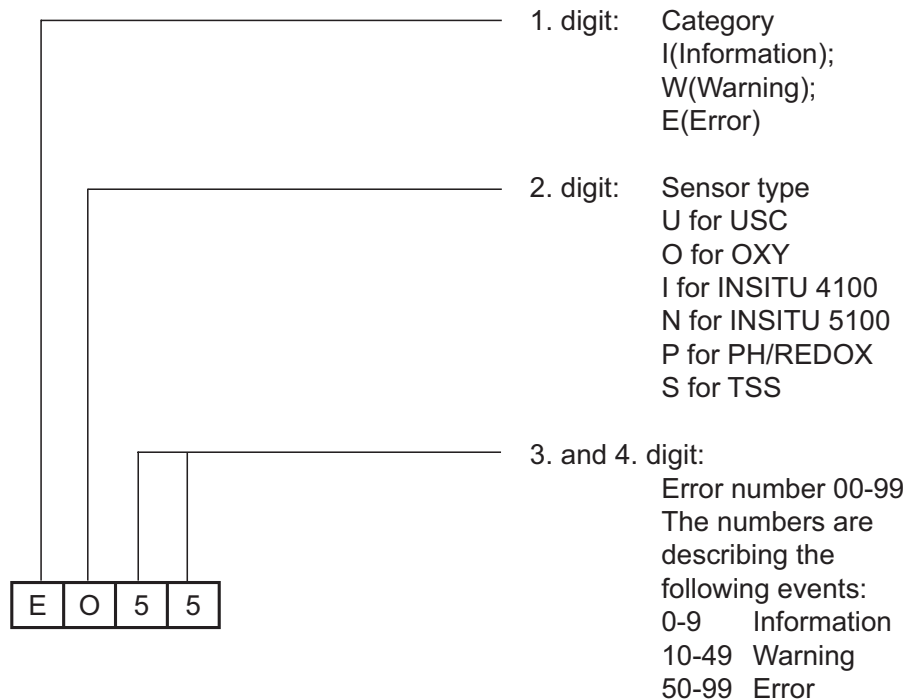

Fig. 50

Each event has an unambiguous identification consisting of 4 digits:



EO55: The OXY 1100 diaphragm has been damaged.

Information

The system will continue to measure as usual. Relay and output signals will not be affected.

Warning

The system will continue to measure, but there has been an event, which may cause malfunction of the system, and which may require an operator. The reason for the warning may disappear on its own. Warning relay, if defined, will show warning in accordance with the setup.

Error

The whole system or parts of it is malfunctioning, and the output signal is not reliable anymore. The errors require an operator. Error relays, if defined, will show error in accordance with the setup.

The EVITA® OXY transmitter error pending list shows the 5 latest occurred errors that are still pending, and the event log shows the 25 latest events, i.e. informations, warnings and errors.

The USC signal converter error pending list can show up to 14 pending errors and warnings, displayed with the USC errors first and then the transmitter errors. If there are more than 14 pending errors, the message “Additional errors cannot be viewed” will show in the display. The USC event log shows the 9 latest events.

Troubleshooting guide - OXY 4100/3150/4150 stand alone transmitter

Symptom	Current signal	Fault	Remedy
Constant current signal (varying oxygen concentration)	I = 0 mA	Incorrect wiring	Check wiring and make the necessary corrections.
		Undervoltage	Check the supply voltage at transmitter. Supply voltage must be at least 12 V.
		Initialisation fault	1. Switch off transmitter for min. 5 seconds. 2. Switch on again while sensor points downwards.
		Transmitter defective	Replace transmitter
	I = 3.80 mA or 24.0 mA	Initialisation fault	1. Switch off transmitter for min. 5 seconds. 2. Switch on again while sensor points downwards.
		Transmitter defective	Replace transmitter
	I = 3.85 mA or 23.5 mA	Membrane leakage	Replace OXY 1100 sensor.
		Moisture behind OXY 1100 sensor	Fully dry the terminals at transmitter. A hair dryer might be of assistance.
I = 3.90 mA or 23.0 mA	Calibration not possible, worn OXY 1100 sensor	Replace OXY 1100 sensor.	
I = 3.95 mA	Oxygen under set measuring range	Set the lower measuring limit to a lower value.	
I = 22.00 mA	Oxygen level higher than set measuring range	Set the upper measuring limit to a higher value.	
Error in measuring value	Variable	Calibration value incorrect	1. Check FSO in atmospheric air. Hold the transmitter up in the air with the sensor downwards. Check value against DS/EN 25814 (see appendix IIa) 2. Check zero point (see appendix IIb) 3. In the case of large reading error, recalibrate.

OXY 4100/3150/4150 transmitter

Symptom	Current output signal	Event code	Cause	Remedy
Error in measuring value	Variable		Calibration value incorrect	<ol style="list-style-type: none"> 1. Check FSO in atmospheric air. Hold the transmitter up in the air with the sensor downwards. Check the value against DS/EN 25814 (see appendix IIa) 2. Check zero point (see appendix IIb) 3. In the case of large reading error, recalibrate
Display switching between "Oxygen" and "End of calibration"			End of calibration phase	Go to "Send command" menu and start measuring, see fig. 47, p. 36
Flashing bell in display 	Depending on the settings	WO10	The measured value has exceeded the transmitter output setting	Change upper range in "Basic settings", see fig. 35, p. 26
		WO11	The measured value is below the transmitter output setting	Change lower range in "Basic settings", see fig. 35, p. 26
		WO15	Life time expired. OXY 1100 should be replaced as soon as possible	Replace OXY 1100
		WO20	The temperature of OXY 1100 is below 0°C (32°F). The accuracy might be reduced.	Accuracy reduced
		WO21	The temperature of OXY 1100 is above 40°C (104°F). The accuracy might be reduced.	Accuracy reduced
		EO50	Calibration not possible. OXY 1100 is worn or defective	Replace OXY 1100
		EO51	Output signal from OXY 1100 is too low. OXY 1100 is worn or defective	Replace OXY 1100
		EO55	The OXY 1100 membrane has been damaged	Replace OXY 1100
		EO60	Error in EEPROM	Replace transmitter
		EO61	Error in communication between the μ -controller and the A/D converter or error in the A/D converter	Replace transmitter
		EO62	Error in the input circuit	Replace transmitter
EO63	Error in the temperature circuit	Replace transmitter		

USC

Symptom	Current output	Event code	Cause	Remedy
None	Undefined	IU00	Power on	Registration of time of power on
		IU01	Add-on module applied	Registration of applied add-on module
		IU02	Add-on module defective or removed	Replace or install add-on module
		IU03	Parameter successfully corrected	Information
Empty display			1. Supply voltage 2. USC 5000/6000/7000 defective	1. Check supply voltage 2. Replace USC 5000/6000/7000
Dots in upper line of display	(I out 1)	EU61	See EU61 p. 45	Same as EU61 p. 45
	(I out 2)	EU62	See EU62 p. 45	
	(I out 3)	EU63	See EU63 p. 45	
	(I out 4)	EU64	See EU64 p. 45	
Flashing bell in display 	Undefined	WU10	I out 1: Value at 4 mA \geq Value at 20 mA	Check I out 1 setup
		WU11	I out 2: Value at 4 mA \geq Value at 20 mA	Check I out 2 setup
		WU12	I out 3: Value at 4 mA \geq Value at 20 mA	Check I out 3 setup
		WU13	I out 4: Value at 4 mA \geq Value at 20 mA	Check I out 4 setup
		WU14	The measured value has exceeded the current output 1 setting	Change value at 20 mA on I out 1
		WU15	The measured value has exceeded the current output 2 setting	Change value at 20 mA on I out 2
		WU16	The measured value has exceeded the current output 3 setting	Change value at 20 mA on I out 3
		WU17	The measured value has exceeded the current output 4 setting	Change value at 20 mA on I out 4
		WU18	The measured value is below the current output 1 setting	Change value at 4 mA on I out 1
		WU19	The measured value is below the current output 2 setting	Change value at 4 mA on I out 2
		WU20	The measured value is below the current output 3 setting	Change value at 4 mA on I out 3
		WU21	The measured value is below the current output 4 setting	Change value at 4 mA on I out 4

Symptom	Current output	Event code	Cause	Remedy
Flashing bell in display 	Undefined	WU39	HART communication error	Check cables
		WU40	TMS communication error	Replace TMS
		WU41	A parameter is out of range. It could not be replaced by its default value	Fixed at power-up
		WU43	Too many errors at the same time. Some errors are not registered correctly	Power-up USC
		WU49	Internal error	Power-up USC
	One or more current outputs = 3.8 mA or 24 mA	EU60	CAN bus application does not respond. This error is shown when the maximum number of communication attempts is exceeded.	1. Power-up USC 2. Replace USC
	Undefined	EU61	USC unable to read data required for I OUT 1 1. No reply from transmitter 2. Transmitter has got new address 3. Another master conflicts on HART® comm. 4. Supply voltage for transmitter too low 5. Too much noise on current loop 6. Transmitter defective 7. USC defective	1. Check shielding and cable connections 2. Power-up USC 3. Disconnect the other master or set USC to another master, see fig. 51, p. 52 4. Check supply voltage at transmitter, supply voltage must be at least 20 V 5. Check shielding and cable connections 6. Replace transmitter 7. Replace USC
		EU62	USC unable to read data required for I OUT 2 1 - 7: Same as EU61	Same as EU61
		EU63	USC unable to read data required for I OUT 3 1 - 7: Same as EU61	Same as EU61
		EU64	USC unable to read data required for I OUT 4 1 - 7: Same as EU61	Same as EU61

Symptom	Current output	Event code	Cause	Remedy
Flashing bell in display 	Undefined	EU65	USC unable to read data required for relay 1 1 - 7: Same as EU61	Same as EU61
		EU66	USC unable to read data required for relay 2 1 - 7: Same as EU61	Same as EU61
		EU67	USC unable to read data required for relay 3 1 - 7: Same as EU61	Same as EU61
		EU68	USC unable to read data required for relay 4 1 - 7: Same as EU61	Same as EU61
		EU69	USC unable to read data required for relay 5 1 - 7: Same as EU61	Same as EU61

Technical Data

Transmitter

Measurement	Clark's principle
Transmitter cable	Two-wire, screened cable 2 x 0.75 mm ² (18 AWG) cable, length 10 m (33')
Supply voltage	Min. 12 Vd.c. - max. 30 Vd.c. HART®: max. ripple (47 Hz - 125 Hz): 0.2 V p-p max. noise (500 Hz - 10 kHz): 1.2 mV rms
Power consumption	Max. 720 mVA
Current output	3.80-24 mA
Time constant	10-300 s (default 40 s)
Digital communication	HART® communication superposed on current output
Alarm signal	On current output (see section "Trouble shooting")
Measuring range (can be configured)	Transmitter: OXY 3150: 4 - 50 ppm or mg/l; 40 - 500 % OXY 4100/4150: 0 - 50 ppm or mg/l; 0 - 500 % Min. span: 1 ppm or mg/l; 10 %
	Sensor (recommended values to maintain operating life): OXY 1100, 25 µm: 0.002 - 2 ppm OXY 1100, 50 µm: 0.1 - 10 ppm OXY 1100, 125 µm: 2 - 50 ppm
Temperature range	Transmitter: Operation: -40°C - +60°C (-40°F to 140°F) Storage/transport: -40°C - +70°C (-40°F to 158°F)
	Sensor: Operation: 0°C - +50°C (32°F to 122°F) Storage/transport: 0°C - +70°C (32°F to 158°F)
	Measured media: 0°C - +40°C (32°F to 104°F)

System accuracy	<i>Digital output:</i> ±0.1 % of FSO at calibrating temperature <i>Analogue output:</i> ±0.2 % of FSO at calibrating temperature <i>Digital/analogue output:</i> ±0.5 % of FSO at 0 - 40°C (32°F to 104°F)
Reaction time OXY 1100	25 µm: τ = 7 s 50 µm: τ = 22 s 125 µm: τ = 110 s
Diaphragm leakage monitoring	Measurement between anode and a terminal in contact with the measured medium
Enclosure	OXY 4100: IEC 529: IP 68 (1 m); NEMA 6P (3') OXY 3150/4150: IEC 529: IP 68 (10 m); NEMA 6P (30')
Dimensions and weight	OXY 4100: d = 240 mm (9.6"); 2.7 kg (6 lb) OXY 3150/4150: d = 50 mm; l = 180 mm (d = 2.0"; l = 7.2"); 1 kg (2.2 lb)
Materials	PBT/PC
EMC	Emission: IEC/EN 61000-6-3 Immunity: IEC/EN 61000-6-2

The worn OXY 1100 sensor must be disposed as ordinary industrial waste, and the worn OXY 4100/4150 transmitter must be disposed as electronic waste. Before disposing the OXY 4100/4150, the cable must be cut off and disposed as metallic waste.

Disposal in accordance with EU directive 2002/96/EC

In compliance with EU directive 2002/96/EC, HACH LANGE / the local subsidiary will accept back and dispose of the old instrument at no cost.



ATTENTION!

It is not allowed to dispose of the instrument using municipal waste disposal services. Please talk to your local HACH LANGE contact.

Important: Before returning goods to HACH LANGE, the products must be cleaned properly.

USC

Type	USC 5000	USC 6000	USC 7000
No. of transmitters	1 (point-to-point installation)	1 (point-to-point installation)	15 (multidrop)
Measuring range	Dissolved oxygen: 0 to 10 – 500 % 0 to 0.1 – 50mg/l or ppm Temperature: 0 – 70°C (32°F – 158°F)	Dissolved oxygen: 0 to 10 – 500 % 0 to 0.1 – 50mg/l or ppm Temperature: 0 – 70°C (32°F – 158°F)	Dissolved oxygen: 0 to 10 – 500 % 0 to 0.1 – 50mg/l or ppm Temperature: 0 – 70°C (32°F – 158°F)
Measuring uncertainty	Oxygen: ± 0.5 % Temperature: ± 0.5°C (0.9°F)	Oxygen: ± 0.5 % Temperature: ± 0.5°C (0.9°F)	Oxygen: ± 0.5 % Temperature: ± 0.5°C (0.9°F)
Current outputs	One 4-20 mA (scaleable), 24V active galvanic isolated Max. load: 800 ohm	Two 4-20 mA (scaleable), 24V active galvanic isolated Max. load: 800 ohm	Four 4-20 mA (scaleable), isolated 24V active galvanic Max. load: 800 ohm
Relay outputs	None	3 relay outputs SPST (max. 48 Va.c. or 30 Vrms 4 A)	5 relay outputs SPST (max. 48 Va.c. or 30 Vrms 4 A)
Digital input	Min. 12 to max 30 V d.c. (6 KOhm)	Min. 12 to max 30 V d.c. (6 KOhm)	Min. 12 to max 30 V d.c. (6 KOhm)
Display	Back-lit alphanumeric LCD display	Back-lit alphanumeric LCD display	Back-lit alphanumeric LCD display
Enclosure	IP 67 according to IEC 529; NEMA 4X	IP 67, IP 20 according to IEC 529; NEMA 4X	IP 67, IP 20 according to IEC 529; NEMA 4X
Ambient temperature	Storage: -40°C to +70°C (-40°F to 158°F) Operation: -40°C to +60°C (-40°F to 140°F)	Storage: -40°C to +70°C (-40°F to 158°F) Operation: -40°C to +60°C (-40°F to 140°F)	Storage: -40°C to +70°C (-40°F to 158°F) Operation: -40°C to +50°C (-40°F to 122°F)
Environment	Indoor use, altitude up to 2000 m Pollution Degree II Relative humidity 80% up to 31°C (87.8°F) decreasing linearly to 50% at 40°C (104°F)	Indoor use, altitude up to 2000 m Pollution Degree II Relative humidity 80% up to 31°C (87.8°F) decreasing linearly to 50% at 40°C (104°F)	Indoor use, altitude up to 2000 m Pollution Degree II Relative humidity 80% up to 31°C (87.8°F) decreasing linearly to 50% at 40°C (104°F)
Power supply	100-240 Vac +10%/-15% 50/60 Hz. 5-20VA Fuse: T500mA/250V (Not to be changed by user)	100-240 Vac +10%/-15% 50/60 Hz. 5-20VA Fuse: T500mA/250V (Not to be changed by user)	100-240 Vac +10%/-15% 50/60 Hz. 5-20VA Fuse: T500mA/250V (Not to be changed by user)
		11-30 Va.c./d.c. 5-20 W	11-30 Va.c./d.c. 5-20 W
Automatic calibration	Compensating for temperature, barometric pressure, humidity and salinity	Compensating for temperature, barometric pressure, humidity and salinity	Compensating for temperature, barometric pressure, humidity and salinity
Cable glands	Jacob GmbH, cat. no. 50.013 PA (PG13.5) 6-12 mm cable diameter	Jacob GmbH, cat. no. 50.013 PA (PG13.5) 6-12 mm cable diameter	Jacob GmbH, cat. no. 50.013 PA (PG13.5) 6-12 mm cable diameter
Blind plugs	Jacob GmbH, cat. no. 1013 PA	Jacob GmbH, cat. no. 1013 PA	Jacob GmbH, cat. no. 1013 PA
Approvals	CE and C-tick approved Emission: EN 50081 Immunity: EN 50082	CE and C-tick approved Emission: EN 50081 Immunity: EN 50082	CE and C-tick approved Emission: EN 50081 Immunity: EN 50082

The insulation between mains supply and all input and output terminals of the USC signal converter were provided with double or reinforced insulation by a dielectric strength voltage of 2300 Va.c. Installation category II.

The worn USC 5000/6000/7000 must be disposed as ordinary electronic waste.

Important: Before returning goods to HACH LANGE, the products must be cleaned properly.

HART®

The OXY 4100/4150/3150 offers additional features which can be accessed through the USC 5000/6000/7000 signal converter or HART® communication. To use HART® communication it is necessary to use a PC or PLC with a HART® modem and associated software.

All *Universal Commands* are fully implemented, as are the necessary *Common Practice Commands*, but to ensure complete utilisation of the transmitter, special *Device Specific Commands* are used.

HART® communication makes it possible to read off:

- oxygen concentration
- temperature
- remaining lifetime of the OXY 1100 sensor
- alarms
- indication of completed calibration

When calibrating/replacing an OXY 1100 sensor the following can be performed with HART® communication:

- initiation of calibration
- keying in of values for relative humidity, air pressure and salinity for compensation purposes
- zero setting of life counter

The USC 5000/6000/7000 can act as either a primary master or a secondary master. This can be set as shown in fig. 51.

The following programming is possible with HART® communication:

- setting of measuring range
- deactivation of tilt-switch for initiating an automatic calibration
- setting of current output signal during calibration for 4 mA, 20 mA or last measuring value
- deactivation of alarms on current output
- measurement start after completed calibration
- change OXY 1100 sensor type

Fig. 51

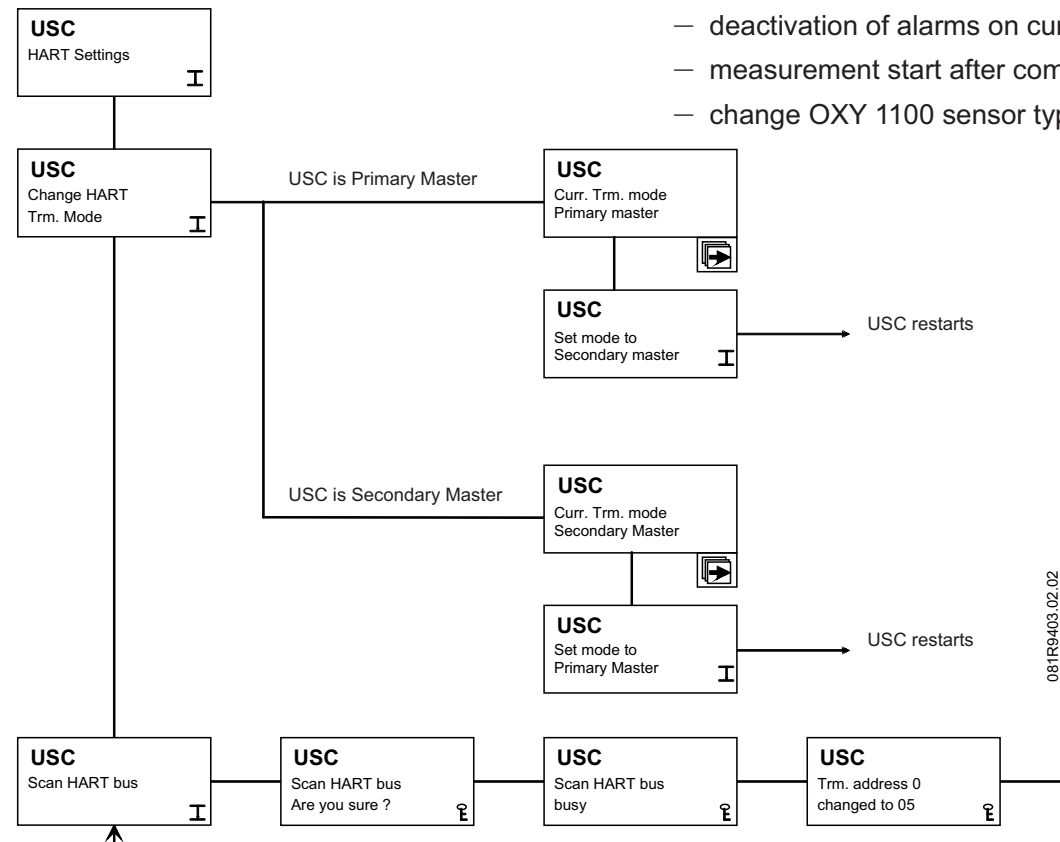

Appendix I

Factory set values and the significance of deviations from them

Parameter	Factory setting	Deviation	Significance (% of actual value)
Atmospheric air pressure	1013.25 mbar	10 mbar	approx. 1
Relative humidity	100%	10%	approx 0.3
Salinity	0 g/l	1 g/l	approx. 1

Appendix IIa

Temperature	Solubility of oxygen in water in equilibrium with air ($\approx 100\%$) at 101.325 kPa
$^{\circ}\text{C}/^{\circ}\text{F}$	mg/l or ppm
0 / 32.0	14.62
1 / 33.8	14.22
2 / 35.6	13.83
3 / 37.4	13.46
4 / 39.2	13.11
5 / 41.0	12.77
6 / 42.8	12.45
7 / 44.6	12.14
8 / 46.4	11.84
9 / 48.2	11.56
10 / 50.0	11.29
11 / 51.8	11.03
12 / 53.6	10.78
13 / 55.4	10.54
14 / 57.2	10.31
15 / 59.0	10.08

Temperature	Solubility of oxygen in water in equilibrium with air ($\approx 100\%$) at 101.325 kPa
$^{\circ}\text{C}/^{\circ}\text{F}$	mg/l or ppm
16 / 60.8	9.87
17 / 62.6	9.66
18 / 64.4	9.47
19 / 66.2	9.28
20 / 68.0	9.09
21 / 69.8	8.91
22 / 71.6	8.74
23 / 73.4	8.58
24 / 75.2	8.42
25 / 77.0	8.26
26 / 78.8	8.11
27 / 80.6	7.97
28 / 82.4	7.83
29 / 84.2	7.69
30 / 86.0	7.56

Source: DS/EN 25814

Appendix IIb

Zero point check

1 g of sodium sulphite (Na_2SO_3) and 1 mg cobalt (II) salt (Cobalt(II)chloride-hexahydrate; $\text{CoCl}_2, 6\text{H}_2\text{O}$) is added to 1 litre of water to remove oxygen from the water. The water is then stirred and oxygen concentration measured in order to check the zero point.

Source: DS/EN 25814

Warranty, liability and complaints

HACH LANGE GmbH warrants that the product supplied is free of material and manufacturing defects and undertakes the obligation to repair or replace any defective parts at zero cost (no guarantee of quality or durability).

At variance with our general terms and conditions, the warranty period for the EVITA series instruments is 12 months.

EVITA INSITU/ EVITA INLINE: On the conclusion of a system care contract within 6 months of purchase, the warranty period is extended based on the terms in the system care contract. HACH LANGE GmbH offers various system care contracts with different services and warranty period extensions.

With the exclusion of the further claims, the supplier is liable for defects including the lack of assured properties as follows: all those parts that, within the warranty period calculated from the day of the transfer of risk, can be demonstrated to have become unusable or that can only be used with significant limitations due to a situation present prior to the transfer of risk, in particular due to incorrect design, poor materials or inadequate finish will be improved or replaced, at the supplier's discretion. The identification of such defects must be notified to the supplier in writing without delay, however at the latest 14 days after the identification of the fault. If the customer fails to notify the supplier, the product is considered approved despite the defect. Further liability for any direct or indirect damages is not accepted.

If instrument-specific maintenance and servicing work defined by the supplier is to be performed within the warranty period by the customer (maintenance) or by the supplier (servicing) and these requirements are not met, claims for damages due to the failure to comply with the requirements are rendered void.

HACH LANGE is not responsible for any indirect or consequential damages, e.g. injuries or damage to property, failure in operation, including loss of production, loss of profits, loss of goods in stock or similar that could result from defects and/or delayed delivery of products sold, irrespective of the cause including faulty manufacture, design and materials.

Furthermore, the warranty does not include:

- Wearing parts and consumables
- If the product is damaged because it was not operated/maintained in accordance with the manual
- If the product is damaged due to incorrect installation or operation
- Damage caused by electrical failure or lightning/ overvoltage
- Defects resulting from failure to clean prior to storage
- Defects due to use outside the specifications for the transmitter

The following points are to be undertaken (even without a system care contract) by the customer:

- Attention! EVITA INSITU 4100 / EVITA INSITU 2100 / EVITA INLINE 4150:
 - o The transmitter is to be cleaned with a cleaning cartridge prior to every chemical change
- Documentation of the cleaning and maintenance work performed
- The replacement of a transmitter supplied
- The cleaning, packaging and organisation of the return of the faulty transmitter to HACH-LANGE for repair and/or troubleshooting

HACH LANGE GmbH process instruments are of proven reliability in many applications and are therefore often used in automatic control loops to provide the most economical possible operation of the related process.

To avoid or limit consequential damage, it is therefore recommended to design the control loop such that a malfunction in an instrument results in an automatic change over to the backup control system; this is the safest operating state for the environment and the process.

If not otherwise agreed, the general terms and conditions of HACH LANGE GmbH also apply

Contacts

Please find below the extract of HACH LANGE companies. Other company locations:
www.hach-lange.com

HACH LANGE GmbH
Willstätterstraße 11
D-40549 Düsseldorf
Tel. +49 (0) 211- 52 88 - 0
Fax +49 (0) 211- 52 88 - 143
info@hach-lange.de
www.hach-lange.de

HACH LANGE LTD
Pacific Way
Salford
Manchester, M50 1DL
Tel. +44 (0)161 8 72 14 87
Fax +44 (0)161 8 48 73 24
info@hach-lange.co.uk
www.hach-lange.co.uk

HACH LANGE
HACH SAS
33, Rue du Ballon
F-93165 Noisy Le Grand
Tél. +33 (0)1 48 15 8080
Fax +33 (0)1 48 15 80 00
info@hach-lange.fr
www.hach-lange.fr

DR. BRUNO LANGE
GES. MBH
Industriestraße 12
A-3200 Obergrafendorf
Tel. +43 (0) 2747 - 74 12
Fax +43 (0) 2747 - 42 18
info@hach-lange.at
www.hach-lange.de

DR. BRUNO LANGE AG
Juchstrasse 1
CH-8604 Hegnau
Tel. +41 (0)44- 9 45 66 10
Fax +41 (0)44- 9 45 66 76
info@hach-lange.ch
www.hach-lange.ch

HACH LANGE SA
Motstraat 54
B-2800 Mechelen
Tél. +32 (0)15 42 35 00
Fax +32 (0)15 41 61 20
info@hach-lange.be
www.hach-lange.be

DR. LANGE NEDERLAND B.V.
Laan van Westroijen 2a
NL-4003 AZ Tiel
Tel. +31(0)3 44 63 11 30
Fax +31(0)3 44 63 11 50
info@hach-lange.nl
www.hach-lange.nl

HACH LANGE AB
Vinhundsvägen159A
S-128 62 Sköndal
Tel. +46 (0)8 7 98 05 00
Fax +46 (0)8 7 98 05 30
info@hach-lange.se
www.hach-lange.se

HACH LANGE A/S
Åkandevej 21
DK-2700 Brønshøj
Tel. +45 36 77 29 11
Fax +45 36 77 49 11
info@hach-lange.dk
www.hach-lange.dk

HACH LANGE S.L.U.
C/Araba 45, Apdo. 220
E-20800 Zarautz/Guipúzcoa
Tel. +34 9 43 89 43 79
Fax +34 9 43 13 02 41
info@hach-lange.es
www.hach-lange.es

HACH LANGE SP.ZO.O.
ul. Opolska 143 a
PL-52-013 Wroclaw
Tel. +48 71 3 42 10-81
Fax +48 71 3 42 10-79
info@hach-lange.pl
www.hach-lange.pl

HACH LANGE S.R.L.
Via Riccione, 14
I-20156 Milano
Tel. +39 02 39 23 14-1
Fax +39 02 39 23 14-39
info@hach-lange.it
www.hach-lange.it

HACH LANGE S.R.O.
Lešanská 2a/1176
CZ-141 00 Praha 4
Tel. +420 272 12 45 45
Fax +420 272 12 45 46
info@hach-lange.cz
www.hach-lange.cz

HACH LANGE S.R.O.
Sabinovská 10
SK-821 02 Bratislava
Tel. +421 2 4820 9091
Fax +421 2 4820 9093
info@hach-lange.sk
www.hach-lange.com

HACH LANGE LDA
Rua dos Malhães,
Edif. D. Pedro I
P-2770-071 Paço D'Arcos
Tel. +351 210 00 1750
Fax +351 210 00 8140
info@hach-lange.pt
www.hach-lange.pt