

JUMO GmbH & Co. KG

Delivery address: Mackenrodtstraße 14
36039 Fulda, Germany
Postal address: 36035 Fulda, Germany
Phone: +49 661 6003-0
Fax: +49 661 6003-607
E-mail: mail@jumo.net
Internet: www.jumo.net

JUMO Instrument Co. Ltd.

JUMO House
Temple Bank, Riverway
Harlow, Essex CM20 2DY, UK
Phone: +44 1279 635533
Fax: +44 1279 635262
E-mail: sales@jumo.co.uk
Internet: www.jumo.co.uk

JUMO Process Control, Inc.

6733 Myers Road
East Syracuse, NY 13057, USA
Phone: 315-437-5866
1-800-554-5866
Fax: 315-437-5860
E-mail: info.us@jumo.net
Internet: www.jumousa.com



JUMO tecLine HD pH and JUMO tecLine HD Rd

pH and redox combination electrodes in glass shaft version

Series 201021 — pH electrodes

Series 201026 — redox electrodes

Brief description

JUMO tecLine HD electrodes are high-quality sensors for highly demanding applications in process and industrial measurement technology. The electrodes benefit from the use of high-quality materials and components. They take the form of combination electrodes (glass or metal electrode and a reference electrode in one shaft). A temperature probe can also be integrated as an option, depending on the type.

JUMO tecLine HD sensors represent the state of the art in modern pH and redox electrodes. Each top-quality electrode is individually tested and supplied with a calibration certificate. Modern production facilities ensure consistent characteristics.

General information on the design of the JUMO tecLine HD series:

All standard electrodes are manufactured using physiologically safe and FDA-listed materials. The sensors feature lead-free shaft glass and therefore comply with the RoHS-2 directive.



Type 201021/10...

Typical areas of application

Chemical industry:

- Process water, high process pressures up to 13 bar, broad temperature range up to a maximum of 135 °C and wide pH range from pH 0 to pH 14

Industrial wastewater engineering:

- Process wastewater, wastewater with highly contaminating media (presence of oil or electrode poisons)

Electroplating:

- Process water, media with electrode poisons (metal ions, complexing agents)

Power stations and waste incineration plants (flue gas scrubbing):

- Wide pH range of pH 0 to pH 14, presence of fine ash particles

Sugar industry:

- Constantly high temperature, presence of electrode poisons (such as sulfides)

Special features

- Low-maintenance thanks to dirt-repellant PTFE ring diaphragm with polymerized highly elastic gel
- Designed for use at continually high process temperature of up to a maximum of 135 °C¹
- For process pressures up to 13 bar
- Pt1000 temperature probe can be integrated as an option
- With salt reserve to increase service life in media with low conductivity
- Long service life with presence of electrode poisons thanks to double-chamber version
- Redox versions with platinum or gold tip up to ±2000 mV

¹ 135 °C for electrodes with VarioPin (VP) plug head
100 °C for electrodes with N plug head (S8)

JUMO GmbH & Co. KG
 Delivery address: Mackenrodtstraße 14
 36039 Fulda, Germany
 Postal address: 36035 Fulda, Germany
 Phone: +49 661 6003-0
 Fax: +49 661 6003-607
 E-mail: mail@jumo.net
 Internet: www.jumo.net

JUMO Instrument Co. Ltd.
 JUMO House
 Temple Bank, Riverway
 Harlow, Essex CM20 2DY, UK
 Phone: +44 1279 635533
 Fax: +44 1279 635262
 E-mail: sales@jumo.co.uk
 Internet: www.jumo.co.uk

JUMO Process Control, Inc.
 6733 Myers Road
 East Syracuse, NY 13057, USA
 Phone: 315-437-5866
 1-800-554-5866
 Fax: 315-437-5860
 E-mail: info.us@jumo.net
 Internet: www.jumousa.com



Technical data

Specifications

Measurands	pH-value Temperature (optional)
Measuring range	0 to 14 pH
Temperature range	0 up to 135 °C

Environmental conditions

Storage temperature	-5 to +30 °C
Protection type	
Variopin (VP) plug head	IP68
N plug head (S8)	IP68

Process conditions

Process temperature	
Variopin (VP) plug head	0 to +135 °C
N screw head (S8)	0 to +100 °C
Process pressure	13 bar
Pressure-temperature diagram	<p>A: N screw head (S8) B: Variopin (VP) plug head</p>
Recommended minimum conductivity	50 µS/cm

Design

Process connection	Pg13.5
Temperature sensor	Pt1000 (class A)
Plug heads	N screw head (S8), Pg13.5 thread Variopin (VP) plug head, Pg13.5 thread
Reference system	Pressure-compensated double-chamber system , silver/silver chloride (Ag/AgCl) cartridge-style conduction system, highly elastic gel (AgCl-free)
Diaphragm	
Exterior	PTFE ring diaphragm
Interior	Ceramic diaphragm ^a
Glass membrane	Spherical
Membrane glass	High-temperature (HT) glass
Materials	See illustrations in chapter „Dimensions“, page 4

^a In double chamber

JUMO GmbH & Co. KG
Delivery address: Mackenrodtstraße 14
36039 Fulda, Germany
Postal address: 36035 Fulda, Germany
Phone: +49 661 6003-0
Fax: +49 661 6003-607
E-mail: mail@jumo.net
Internet: www.jumo.net

JUMO Instrument Co. Ltd.
JUMO House
Temple Bank, Riverway
Harlow, Essex CM20 2DY, UK
Phone: +44 1279 635533
Fax: +44 1279 635262
E-mail: sales@jumo.co.uk
Internet: www.jumo.co.uk

JUMO Process Control, Inc.
6733 Myers Road
East Syracuse, NY 13057, USA
Phone: 315-437-5866
1-800-554-5866
Fax: 315-437-5860
E-mail: info.us@jumo.net
Internet: www.jumousa.com



Special design features

Salt reserve

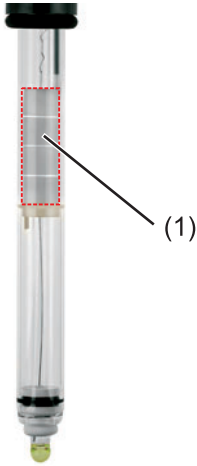

The electrode is equipped as standard with a salt reserve in the form of four salt rings (see illustration).

This makes it particularly well suited to use in low-ion media or at high flow rates.

The salt reserve helps to improve the service life of the electrode.

The rings are not a manufacturing defect (crystallization).

(1) Salt reserve

Double chamber

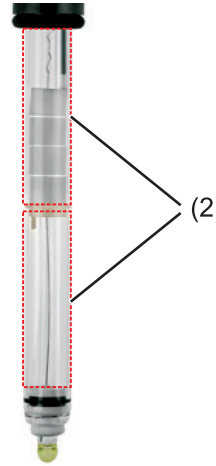

If electrode poisons such as sulfides are present in the measurement medium, the extended diffusion path (due to the two consecutive chambers – double chamber system) and the double diaphragm separation prevent electrode poisoning.

(2) Double chamber

JUMO GmbH & Co. KG
 Delivery address: Mackenrodtstraße 14
 36039 Fulda, Germany
 Postal address: 36035 Fulda, Germany
 Phone: +49 661 6003-0
 Fax: +49 661 6003-607
 E-mail: mail@jumo.net
 Internet: www.jumo.net

JUMO Instrument Co. Ltd.
 JUMO House
 Temple Bank, Riverway
 Harlow, Essex CM20 2DY, UK
 Phone: +44 1279 635533
 Fax: +44 1279 635262
 E-mail: sales@jumo.co.uk
 Internet: www.jumo.co.uk

JUMO Process Control, Inc.
 6733 Myers Road
 East Syracuse, NY 13057, USA
 Phone: 315-437-5866
 1-800-554-5866
 Fax: 315-437-5860
 E-mail: info.us@jumo.net
 Internet: www.jumousa.com



Dimensions

Type 201021/10...

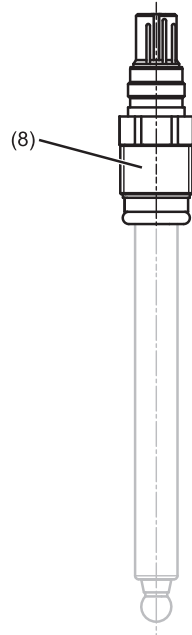
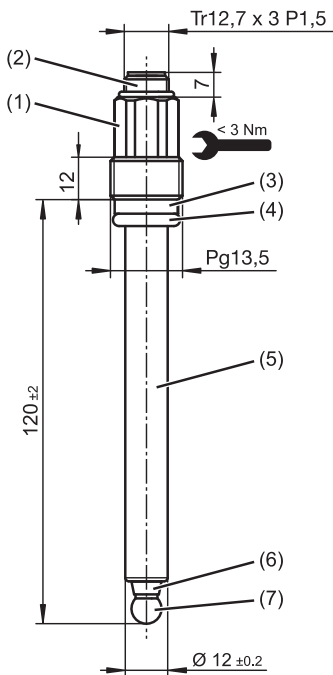

- (1) N screw head (S8) Pg13.5 (POM), max. tightening torque 3 Nm
- (2) Thread Tr12.7 × 3 P1.5
- (3) Ring (PSU)
- (4) O-ring 10 × 3.5 (FPM70)
- (5) Electrode shaft (glass DIN 19263)
- (6) Ring diaphragm (PTFE)
- (7) Tip membrane
- (8) Variopin (VP) plug head connection variant

Type 201026/10...

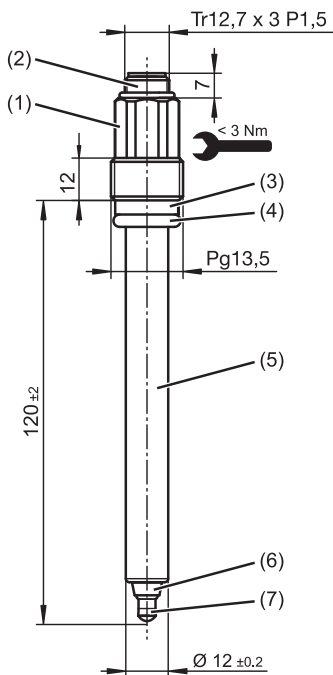

- (1) N screw head (S8) Pg13.5 (POM), max. tightening torque 3 Nm
- (2) Thread Tr12.7 × 3 P1.5
- (3) Ring (PSU)
- (4) O-ring 10 × 3.5 (FPM70)
- (5) Electrode shaft (glass DIN 19263)
- (6) Ring diaphragm (PTFE)
- (7) Platinum or gold tip

JUMO GmbH & Co. KG
 Delivery address: Mackenrodtstraße 14
 36039 Fulda, Germany
 Postal address: 36035 Fulda, Germany
 Phone: +49 661 6003-0
 Fax: +49 661 6003-607
 E-mail: mail@jumo.net
 Internet: www.jumo.net

JUMO Instrument Co. Ltd.
 JUMO House
 Temple Bank, Riverway
 Harlow, Essex CM20 2DY, UK
 Phone: +44 1279 635533
 Fax: +44 1279 635262
 E-mail: sales@jumo.co.uk
 Internet: www.jumo.co.uk

JUMO Process Control, Inc.
 6733 Myers Road
 East Syracuse, NY 13057, USA
 Phone: 315-437-5866
 1-800-554-5866
 Fax: 315-437-5860
 E-mail: info.us@jumo.net
 Internet: www.jumousa.com



Order details type 201021

(1) Basic type	
201021/10	JUMO tecLine HD pH – pH combination electrode in glass shaft version, solid gel, double chamber, salt reserve, 13 bar
(2) Active pH component	
12	HT glass
(3) Diaphragm	
04	PTFE ring
(4) Electrical connection	
18	VarioPin (VP) plug head Pg13.5
22	N screw head (S8) Pg13.5
(5) Insertion length	
120.0	120 mm (standard)
225.0	225 mm
(6) Extra code	
000	None
841	Integrated Pt1000

	(1)		(2)		(3)		(4)		(5)		(6)
Order code		-		-		-		-		/	
Order example	201021/10	-	12	-	04	-	22	-	120	/	000

Important information:

The order code is not modular. When placing orders, if possible please select the items listed under "**Stock versions**" or "**Production versions**". We must check the technical feasibility of and approve freely chosen combinations of individual code parts.

JUMO GmbH & Co. KG

Delivery address: Mackenrodtstraße 14
36039 Fulda, Germany
Postal address: 36035 Fulda, Germany
Phone: +49 661 6003-0
Fax: +49 661 6003-607
E-mail: mail@jumo.net
Internet: www.jumo.net

JUMO Instrument Co. Ltd.

JUMO House
Temple Bank, Riverway
Harlow, Essex CM20 2DY, UK
Phone: +44 1279 635533
Fax: +44 1279 635262
E-mail: sales@jumo.co.uk
Internet: www.jumo.co.uk

JUMO Process Control, Inc.

6733 Myers Road
East Syracuse, NY 13057, USA
Phone: 315-437-5866
1-800-554-5866
Fax: 315-437-5860
E-mail: info.us@jumo.net
Internet: www.jumousa.com



Order details type 201026

(1) Basic type	
201026/10	JUMO tecLine HD Rd – Rd combination electrode in glass shaft version, solid gel, double chamber, salt reserve, 13 bar
(2) Active pH component	
22	Pt (platinum) tip
32	Au (gold) tip
(3) Diaphragm	
04	PTFE ring
(4) Electrical connection	
22	N screw head (S8) Pg13.5
(5) Insertion length	
120.0	120 mm (standard)
225.0	225 mm
(6) Extra code	
000	None

	(1)		(2)		(3)		(4)		(5)		(6)
Order code	<input type="text"/>	-	<input type="text"/>	-	<input type="text"/>	-	<input type="text"/>	-	<input type="text"/>	/	<input type="text"/>
Order example	201026/10	-	22	-	04	-	22	-	120	/	000

Important information:

The order code is not modular. When placing orders, if possible please select the items listed under "**Stock versions**" or "**Production versions**". We must check the technical feasibility of and approve freely chosen combinations of individual code parts.

JUMO GmbH & Co. KG

Delivery address: Mackenrodtstraße 14
36039 Fulda, Germany
Postal address: 36035 Fulda, Germany
Phone: +49 661 6003-0
Fax: +49 661 6003-607
E-mail: mail@jumo.net
Internet: www.jumo.net

JUMO Instrument Co. Ltd.

JUMO House
Temple Bank, Riverway
Harlow, Essex CM20 2DY, UK
Phone: +44 1279 635533
Fax: +44 1279 635262
E-mail: sales@jumo.co.uk
Internet: www.jumo.co.uk

JUMO Process Control, Inc.

6733 Myers Road
East Syracuse, NY 13057, USA
Phone: 315-437-5866
1-800-554-5866
Fax: 315-437-5860
E-mail: info.us@jumo.net
Internet: www.jumousa.com



Scope of delivery

1 sensor in the ordered version
1 certificate of quality

Stock versions

(Delivery within 3 working days after receipt of order)

Type	Part no.
201021/10-12-04-22-120/000	00621059
201021/10-12-04-18-120/841	00621070
201026/10-22-04-22-120/000	00625340

Accessories

Cable

Item	Part no.
Cable for sensors with N screw head (S8) Pg13.5: 202990/02-92-x-13	See data sheet 202990
Cable for sensors with Variopin (VP) plug head: 202990/11-95-x-11	See data sheet 202990

Solutions

Item	Part no.
pH buffer solutions	See data sheet 202950
Redox reference solution	See data sheet 202950
Electrode cleanser	See data sheet 202950